



INTERNATIONAL
Drill Guide, INC.



Gun Drill and other
deep hole tooling.

Contents

Contents & How to Use This Guide	2
About International Drill Guide, Inc.	3
SnapGuide® Product and Benefits	4-5
17mm OD SnapGuide®	6
20mm OD SnapGuide®	7
30mm OD SnapGuide®	8-9
45mm OD SnapGuide®	10
75mm OD SnapGuide®	11
17, 20, 30, 45, 75mm OD SnapGuide® Specials	12
SnapGuide® for BTA Drills	13
About Drill Guides	14
Drill Guide Sizing Charts	15-16
Special Drill Guides	17-18
BTA Drill Guides	19
About Chip Deflectors	20
Chip Deflectors Sizing Charts and Pricing	21
32 and 40mm O.D. Chip Deflectors	22
Special & Small Diameter Sizes SnapGuide®	23
Drill Guides for Extra Wide Bearings	24
SnapGuides and Drill Guides for Allied Drill	25
SnapGuide® Bushings for Sumo Gun Drills	26
Bearing Adaptor and Free Sample Request	27

How to use this Guide

All part specification pages are arranged with the following helpful guide points as shown below.

Page Subject — 17 MM OD SnapGuide™

Page Number — 6

Part Notes — NOTE: All finished bearings should have round holes. Customer hole location in these cases may contribute to premature chip breakage. Call us for location bearings in this range and we will review your application.

Advice in selecting the best parts. — The BEST SnapGuide™ to use when drilling any hole .001" or smaller.

Pricing Information — PRICING - US Dollars
17 mm OD Bushing

Size Selection Guide

Schematic Size Guide

Part Sizes

Quantity	Quantity Discounts for Individual sizes only	1-24	25-49	50-99	100+	Bearings	Snap Rings
		\$9.75	\$5.25	\$4.25	\$3.25	\$8.00 (500.00)	\$1.25 (100.17)

About International Drill Guide, Inc.

International Drill Guide, Inc. manufactures a full line of plastic support bushings and chip box seals for all deep hole drilling machines. Our products stop drill whipping, reduce vibration, increase hole accuracy and seal the chip box on every gun drill machine. We offer the best application engineering to optimize your job coupled with expertise in Chemistry and Polymers to maximize bushing life and performance. The products are molded on our state of the art CNC molding machine. Specials can be designed and built with minimal lead time in our own CNC mold making shop. Our signature **Blue Bushings®** always guarantee you top quality.

3



The color blue is a registered trademark of International Drill Guide, Inc.

Pricing and specifications subject to change with out notice.

T 864.225.2214 F 864.226.0832
204 Knoxwood Ct.
Anderson, South Carolina 29621 USA

www.gundrill.com



SnapGuide®

Quick-change support bushing held in place with snap ring.

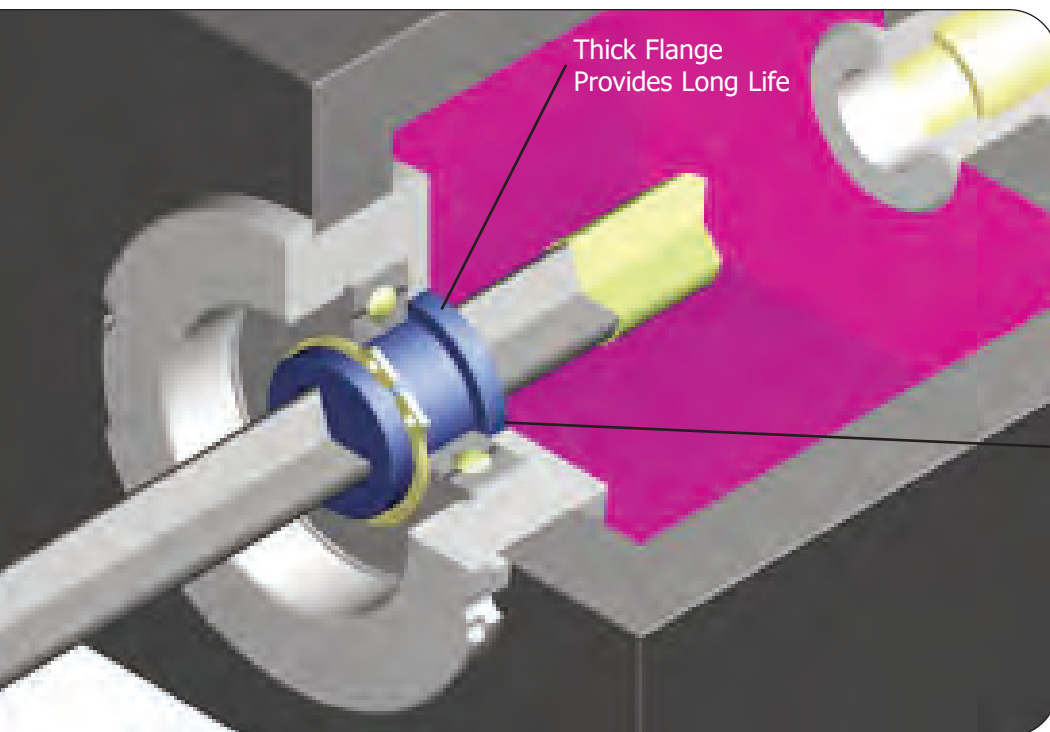
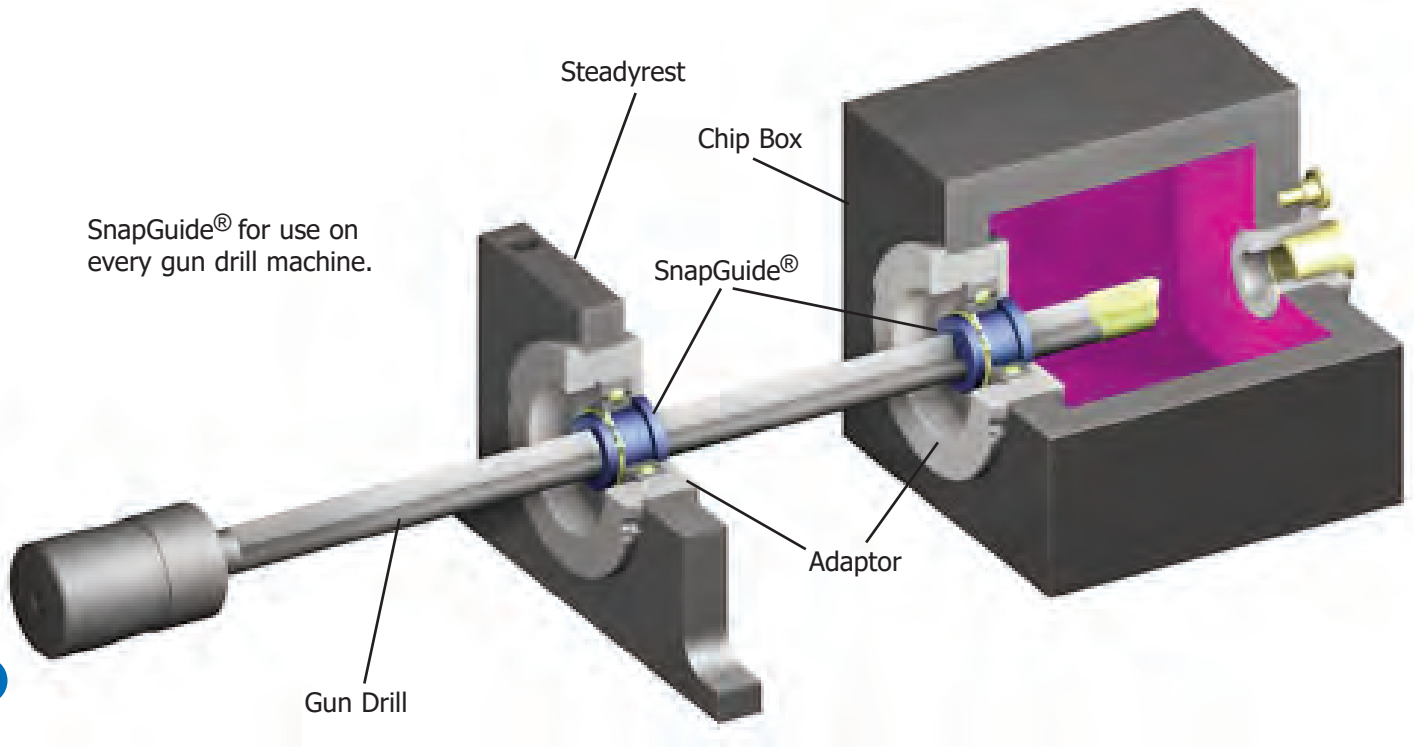

Chip Box

Flexible plastic SnapGuide® bushings stretch over carbide gun drill tip and contract over steel tube to stop drill whipping and vibration. Contoured hole in SnapGuide® forms perfect seal on gun drill.

Our signature **Blue Bushings®** always guarantee you top quality.

Steadyrest

SnapGuide® with round holes are used in the steadyrest. This speeds drill loading by eliminating the need to orient the contoured hole in the SnapGuide® with the drill. Extra clearance in SnapGuide® allows drill tip to slide through easier. Also helps prevent steadyrest from being dragged out of position.

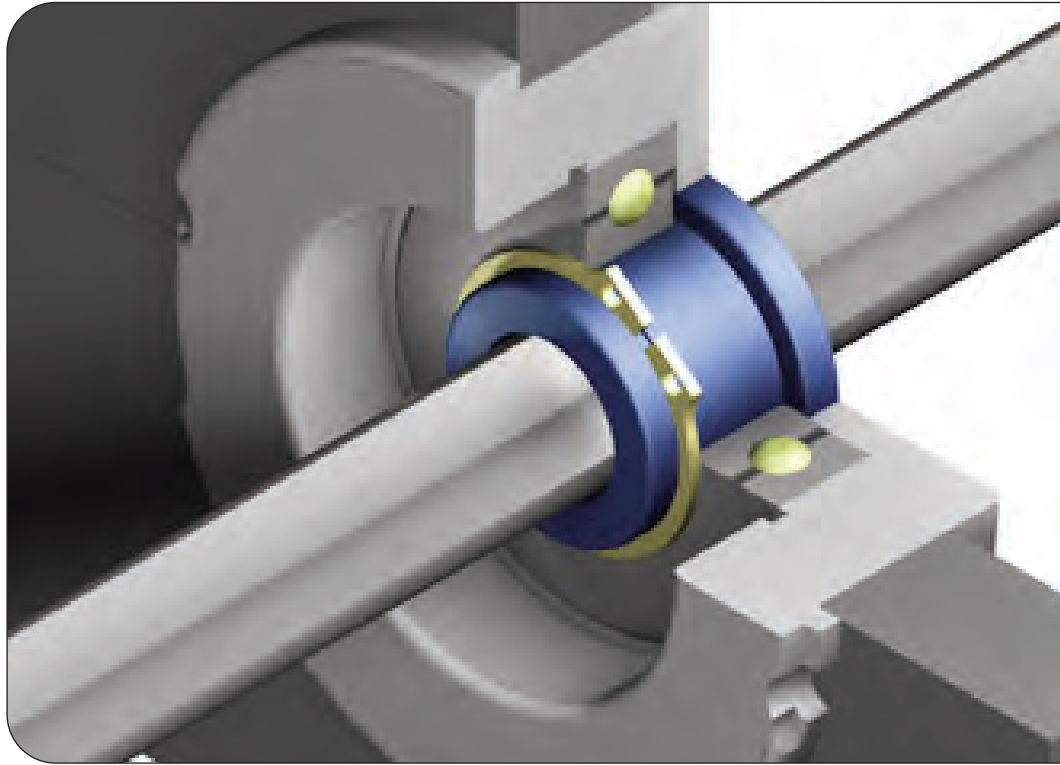

Set Up Reduction

Each bearing holder has large drill range capacity reducing or eliminating holder change-overs on machine.

- SnapGuide® Drill Range**
- 17mm OD - .070 - .509
 - 20mm OD - .070 - .639
 - 30mm OD - .125 - 1.0449
 - 45mm OD - .800 - 1.5199
 - 75mm OD - 1.520 - 2.044+

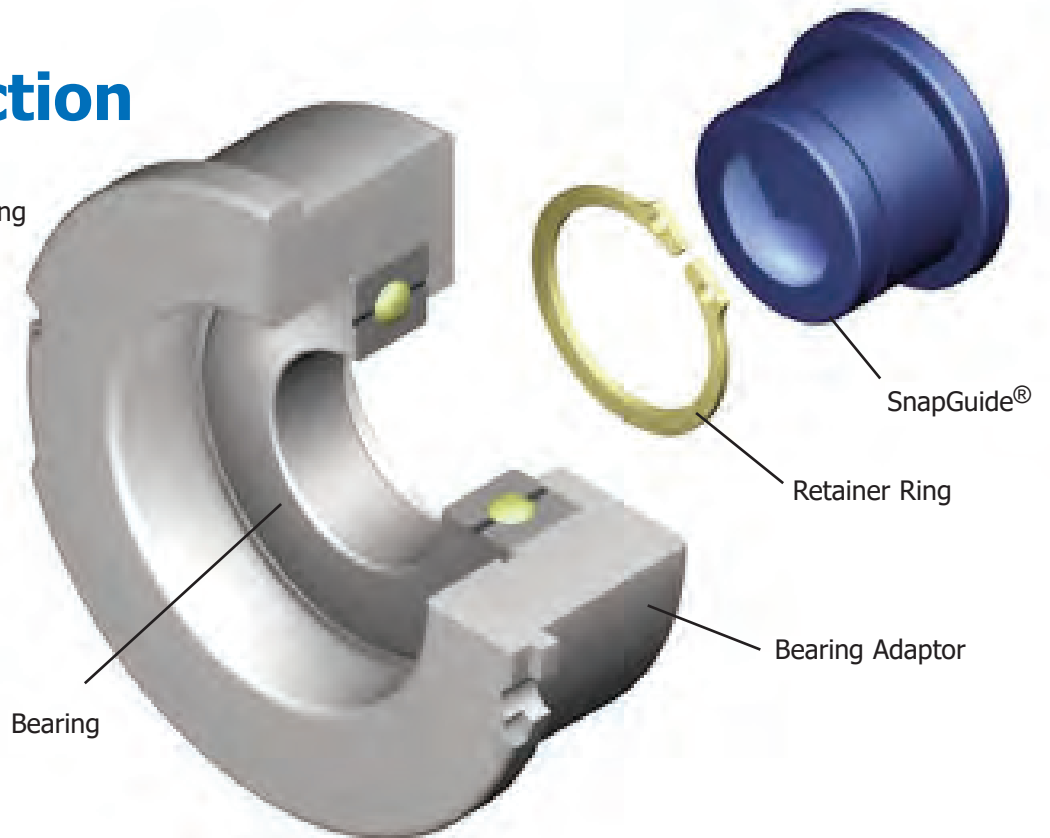

17 mm OD SnapGuide®

INTERNATIONAL Drill Guide, INC. T 864.225.2214 F 864.226.0832 gundrill.com

[Click here to request free 17mm OD SnapGuide sample](#)

6

NOTE

All SnapGuide® bushings shaded **red** have round holes. Contour hole bushings in these ranges may contribute to premature drill breakage. Call us for contour bushings in this range and we will review your application.

The **BEST** SnapGuide® to use when drilling any hole .509" or smaller.

Bushing ID	Standard Part No.	Drill Range	Steadyrest Part No.	Bushing ID
.032	0,8R-17		0,8R-17	.032
.047	1,2R-17		1,2R-17	.047
.054	1,4R-17		1,4R-17	.054
.066	1,67R-17	<=.0769	1,67R-17	.066
.070	1,77R-17	.0770 - .0831	1,77R-17	.070
.074	1,87R-17	.0832 - .0892	1,87R-17	.074
.078	1,97R-17		1,97R-17	.078
.082	2,07R-17	.0883 - .0933	2,07R-17	.082
.085	2,17R-17	.0934 - .0984	2,17R-17	.085
.090	2,27R-17	.0985 - .1010	2,27R-17	.090
.094	2,37R-17	.1011 - .1035	2,37R-17	.094
.097	2,47R-17	.1036 - .1086	2,47R-17	.097
.101	2,57R-17	.1087- .1137	2,57R-17	.101
.105	2,67R-17	.1138 - .1179	2,67R-17	.105
.110	2,8R-17	.1180 - .1239	2,8R-17	.110
.117	3,0R-17	.1240 - .1329	3,0R-17	.117
.125	3,2R-17	.1330 - .1369	3,2R-17	.125
.133	3,4R-17	.1370 - .1430	3,4R-17	.133
.137	3,5R-17	.1431 - .1519	3,5R-17	.137
.143	3,65R-17		3,65R-17	.143
.150	3,8R-17	.1520 - .1609	3,8R-17	.150
.153	3,87-17	.1610 - .1666	4,0R-17	.157
.160	4,07-17	.1667 - .1718	4,27R-17	.171
.168	4,27-17	.1719 - .1823	4,47R-17	.176
.176	4,47-17	.1824 - .1949	4,6R-17	.181
.184	4,67-17	.1950 - .2049	4,8R-17	.189
.192	4,87-17	.2050 - .2099	5,0R-17	.197
.200	5,07-17	.2100 - .2239	5,2R-17	.205
.208	5,27-17	.2240 - .2289	5,4R-17	.213
.216	5,47-17	.2290 - .2399	5,47R-17	.215
.223	5,67-17	.2400 - .2449	5,67R-17	.223
.226	5,75-17	.2450 - .2499	5,75R-17	.226
.236	6,0-17	.2500 - .2599	6,0R-17	.236
.246	6,25-17	.2600 - .2799	6,25R-17	.246
.260	6,6-17	.2800 - .2869	6,6R-17	.260
.272	6,90-17	.2870 - .3079	6,9R-17	.272
.283	7,20-17	.3080 - .3199	7,2R-17	.283
.295	7,50-17	.3200 - .3299	7,45R-17	.293
.307	7,80-17	.3300 - .3399	7,8R-17	.307
.321	8,15-17	.3400 - .3499	8,15R-17	.321
.332	8,45-17	.3500 - .3599	8,45R-17	.333
.341	8,65-17	.3600 - .3699	8,65R-17	.341
.360	9,15-17	.3700 - .3929	9,15R-17	.360
.372	9,45-17	.3930 - .4009	9,45R-17	.372
.384	9,75-17	.4010 - .4059	9,75R-17	.384
.396	10,05-17	.4060 - .4249	10,05R-17	.396
.411	10,45-17	.4250 - .4479	10,45R-17	.411
.427	10,85-17	.4480 - .4629	10,9R-17	.429
.439	11,15-17	.4630 - .4779	11,15R-17	.439
.455	11,55-17	.4780 - .4909	11,55R-17	.455
.463	11,75-17		11,75R-17	.463
.475	12,1-17	.4910 - .5099	12,1R-17	.475

Bearing dimensions 35 mm OD x 10 mm wide x 17 mm bore

Quantity discounts for individual sizes only

1-24	25-47	48-99	100+	Bearings	Snap Rings
\$5.75	\$5.25	\$4.25	\$3.25	\$8.00(6003-2RS)	\$.25 (DSH-17)

PRICING - US Dollars
17mm OD Bushing

Bushing ID	Standard Part No.	Drill Range	Steadyrest Part No.	Bushing ID
.071	1,8R-20	<=.0831	1,8R-20	.071
.075	1,9R-20	.0832 - .0882	1,9R-20	.075
.079	2,0R-20		2,0R-20	.079
.083	2,1R-20	.0883 - .0933	2,1R-20	.083
.087	2,2R-20	.0934 - .0984	2,2R-20	.087
.091	2,3R-20	.0985 - .1010	2,3R-20	.091
.094	2,4R-20	.1011 - .1035	2,4R-20	.094
.098	2,5R-20	.1036 - .1086	2,5R-20	.098
.102	2,6R-20	.1087 - .1137	2,6R-20	.102
.106	2,7R-20	.1138 - .1179	2,7R-20	.106
.110	2,8R-20	.1180 - .1239	2,8R-20	.110
.118	3,0R-20	.1240 - .1329	3,0R-20	.118
.126	3,2R-20	.1330 - .1369	3,2R-20	.126
.134	3,4R-20	.1370 - .1430	3,4R-20	.134
.138	3,5R-20	.1431 - .1519	3,5R-20	.138
.150	3,8R-20	.1520 - .1609	3,8R-20	.150
.157	4,0R-20	.1610 - .1666	4,0R-20	.157
.165	4,2R-20	.1667 - .1718	4,2R-20	.165
.168	4,27-20	.1719 - .1823	4,4R-20	.173
.176	4,47-20	.1824 - .1949	4,47R-20	.176
			4,6R-20	.181
.184	4,67-20	.1950 - .2049	4,67R-20	.184
			4,8R-20	.189
.192	4,87-20	.2050 - .2099	5,0R-20	.197
.200	5,07-20	.2100 - .2239	5,2R-20	.205
.208	5,27-20	.2240 - .2289	5,4R-20	.213
.216	5,47-20	.2290 - .2399	5,47R-20	.215
.223	5,67-20	.2400 - .2449	5,67R-20	.223
.226	5,75-20	.2450 - .2499	5,75R-20	.226
.236	6,0-20	.2500 - .2599	6,0R-20	.236
.246	6,25-20	.2600 - .2799	6,25R-20	.246
.260	6,6-20	.2800 - .2869	6,6R-20	.260
.272	6,9-20	.2870 - .3079	6,9R-20	.272
.283	7,2-20	.3080 - .3199	7,2R-20	.283
.295	7,50-20	.3200 - .3299	7,5R-20	.295
.307	7,8-20	.3300 - .3399	7,80R-20	.307
			8,0R-20	.315
.321	8,15-20	.3400 - .3499	8,15R-20	.321
.333	8,45-20	.3500 - .3599	8,45R-20	.333
.341	8,65-20	.3600 - .3699	8,65R-20	.341
.360	9,15-20	.3700 - .3929	9,15R-20	.360
.372	9,45-20	.3930 - .4009	9,45R-20	.372
.380	9,65-20			
.384	9,75-20	.4010 - .4059	9,75R-20	.384
.396	10,05-20	.4060 - .4249	10,05R-20	.396
.411	10,45-20	.4250 - .4479	10,45R-20	.411
.427	10,85-20	.4480 - .4629	10,85R-20	.427
.439	11,15-20	.4630 - .4779	11,15R-20	.439
.455	11,55-20	.4780 - .4901	11,55R-20	.455
.463	11,75-20	.4902 - .5099	11,75R-20	.463
.488	12,4-20	.5100 - .5249	12,4R-20	.488
.504	12,8-20	.5250 - .5399	12,8R-20	.504
.524	13,3-20	.5400 - .5649	13,3R-20	.524
.543	13,8-20	.5650 - .5799	13,8R-20	.543
.563	14,3-20	.5800 - .5999	14,3R-20	.563
.583	14,8-20	.6000 - .6199	14,8R-20	.583
.600	15,25-20	.6200 - .6399	15,25R-20	.600
.606	15,4-20		15,4R-20	.606

Bearing dimensions 42 mm OD x 12 mm wide x 20 mm bore

Quantity discounts for individual sizes only

1-24	25-47	48-99	100+	Bearings	Snap Rings
\$6.75	\$5.50	\$4.50	\$3.50	\$10.00(6004-2RS)	\$.25 (DSH-20)

20 mm OD SnapGuide®

INTERNATIONAL Drill Guide, INC. T 864.225.2214 F 864.226.0832 gundrill.com

[Click here to request free 20mm OD SnapGuide sample](#)

NOTE
All SnapGuide® bushings shaded **red** have round holes. Contour hole bushings in these ranges may contribute to premature drill breakage. Call us for contour bushings in this range and we will review your application.

The **BEST** SnapGuide® to use for any hole smaller than .629" but larger than .509". Also best when a bushing with total range of .070" - .639" is required.

PRICING - US Dollars
20mm OD Bushing

30 mm OD SnapGuide®

INTERNATIONAL
Drill Guide, INC. T 864.225.2214
F 864.226.0832
gundrill.com

[Click here to request free
30mm OD SnapGuide sample](#)

8

NOTE

All SnapGuide® bushings shaded **red** have round holes. Contour hole bushings in these ranges may contribute to premature drill breakage. Call us for contour bushings in this range and we will review your application.

The **BEST** SnapGuide® for large holes up to 1.0449". Excellent job shop bushing with largest range of any of our bushings. Drill range is .0985"-1.0449".

Bushing ID	Standard Part No.	Drill Range	Steadyrest Part No.	Bushing ID
		Appropriate Drill Sizes		
	Chip Box		Steady Rest	
	SnapGuide®		SnapGuide®	
	30		30	
.090	2,3R-30	.0985 - .1010	2,3R-30	.090
.110	2,8R-30	.1180 - .1239	2,8R-30	.110
.118	3,0R-30	.1240 - .1329	3,0R-30	.118
.126	3,2R-30	.1330 - .1369	3,2R-30	.126
.134	3,4R-30	.1370 - .1430	3,4R-30	.134
.137	3,5R-30	.1431 - .1519	3,5R-30	.137
.149	3,8R-30	.1520 - .1609	3,8R-30	.149
.157	4,0R-30	.1610 - .1666	4,0R-30	.157
.165	4,2R-30	.1667 - .1718	4,2R-30	.165
.173	4,4R-30	.1719 - .1823	4,4R-30	.173
.181	4,6R-30	.1824 - .1949	4,6R-30	.181
.189	4,8R-30	.1950 - .2049	4,8R-30	.189
.197	5,0R-30	.2050 - .2099	5,0R-30	.197
.200	5,07-30	.2100 - .2239	5,2R-30	.204
.208	5,27-30	.2240 - .2289	5,4R-30	.212
.215	5,47-30	.2290 - .2399	5,47R-30	.215
.223	5,67-30	.2400 - .2449	5,6R-30	.220
.226	5,75-30	.2450 - .2499	5,8R-30	.228
.236	6,0-30	.2500 - .2599	6,0R-30	.236
.246	6,25-30	.2600 - .2799	6,25R-30	.246
.260	6,6-30	.2800 - .2869	6,6R-30	.260
			6-8R-30	.268
.272	6,9-30	.2870 - .3079	6,9R-30	.272
.283	7,2-30	.3080 - .3199	7,2R-30	.283
.295	7,50-30	.3200 - .3299	7,45R-30	.293
.307	7,8-30	.3300 - .3399	7,80R-30	.307
.321	8,15-30	.3400 - .3499	8,15R-30	.321
.333	8,45-30	.3500 - .3599	8,45R-30	.332
.341	8,65-30	.3600 - .3699	8,65R-30	.341
			8,81R-30	.347
			8,9R-30	.350
.360	9,15-30	.3700 - .3929	9,15R-30	.360
.372	9,45-30	.3930 - .4009	9,45R-30	.372
.384	9,75-30	.4010 - .4059	9,75R-30	.384
			9,9R-30	.390
.396	10,05-30	.4060 - .4249	10,05R-30	.396
.411	10,45-30	.4250 - .4479	10,45R-30	.411
.427	10,85-30	.4480 - .4629	10,9R-30	.429
.439	11,15-30	.4630 - .4779	11,15R-30	.439
.455	11,55-30	.4780 - .4909	11,55R-30	.455
.463	11,75-30	.4910 - .5099	11,75R-30	.463
			11,9R-30	.469
.488	12,4-30	.5100 - .5249	12,4R-30	.488
.504	12,8-30	.5250 - .5399	12,8R-30	.504
			12,9R-30	.508
.524	13,3-30	.5400 - .5649	13,3R-30	.524
.543	13,8-30	.5650 - .5799	13,8R-30	.543
			13,9R-30	.547
.563	14,3-30	.5800 - .5999	14,3R-30	.563
.583	14,8-30	.6000 - .6199	14,8R-30	.583
			14,9R-30	.587
.600	15,25-30	.6200 - .6399	15,25R-30	.600
.614	15,6-30	.6400 - .6799	15,6R-30	.614

Continued on next page

30mm OD SnapGuide®

CONTINUED

INTERNATIONAL Drill Guide, INC. T 864.225.2214 F 864.226.0832 gundrill.com

[Click here to request free 30mm OD Snap Guide sample](#)

NOTE

All SnapGuide® bushings shaded **red** have round holes. Contour hole bushings in these ranges may contribute to premature drill breakage. Call us for contour bushings in this range and we will review your application.

The **BEST** SnapGuide® for large holes up to 1.0449". Excellent job shop bushing with largest range of any of our bushings. Drill range is .0985"-1.0449".

PRICING - US Dollars
30mm OD Bushing

Bushing ID	Standard Part No.	Drill Range	Steadyrest Part No.	Bushing ID
.630	16,0-30		15,9R-30	.626
.646	16,4-30	.6800 - .6999	16,0R-30	.630
			16,4R-30	.646
.677	17,2-30	.7000 - .7399	16,9R-30	.665
.709	18,0-30	.7400 - .7599	17,2R-30	.677
.740	18,8-30	.7600 - .7999	17,9R-30	.705
			18,8R-30	.740
.778	19,75-30	.8000 - .8399	19,1R-30	.752
			19,75R-30	.778
.819	20,8-30	.8400 - .8699	19,9R-30	.783
			20,8R-30	.819
.845	21,5-30	.8700 - .8799	21,2R-30	.835
.854	21,7-30	.8800 - .9199	21,5R-30	.845
			21,8R-30	.858
.866	22,0-30	.9200 - .9399	21,9R-30	.862
			22,0R-30	.866
.894	22,7-30		22,35R-30	.878
			22,7R-30	.894
.906	23,0-30	.9400 - .9599	22,8R-30	.898
			23,0R-30	.906
.933	23,7-30		23,35R-30	.919
.937	23,8-30		23,8R-30	.937
.945	24,0-30	.9600 - .9799	24,0R-30	.945
.960	24,4-30	.9800 - 1.0049	24,4R-30	.960
.980	24,9-30	1.0050 - 1.0449	24,9R-30	.980

Bearing dimensions 55mm OD x 13mm wide x 30mm bore.

Note: 30 mm OD x 16 mm wide bushings also in stock. To order insert the letter "L" in front of any of the above part numbers. Example- 24,9-30 becomes L24,9-30.

Quantity discounts for individual sizes only

1-24	25-47	48-99	100+	Bearings	Snap Rings
\$7.75	\$6.50	\$6.00	\$5.50	\$13.00 (6006-2RS)	\$.25 (DSH-30)



The color blue is a registered trademark of International Drill Guide, Inc.

Pricing and specifications subject to change with out notice.

Can't find the special bushing you need? Let us quote it!

45 mm OD SnapGuide®

INTERNATIONAL Drill Guide, INC. T 864.225.2214 F 864.226.0832 gundrill.com

Click here to request free 45mm OD SnapGuide sample

10

NOTE
All SnapGuide® bushings shaded **red** have round holes. Contour hole bushings in these ranges may contribute to premature drill breakage. Call us for contour bushings in this range and we will review your application.

For Drills from .1402"-1.5199"

Bushing ID	Standard Part No.	Drill Range	Steadyrest Part No.	Bushing ID
.134	3,4R-45	.1402 - .1496	3,4R-45	.134
.177	4,5R-45	.1870 - .1968	4,5R-45	.177
.187	4,75R-45	.1969 - .2067	4,75R-45	.187
.226	5,75R-45	.2362 - .2460	5,75R-45	.226
.236	6,0R-45	.2461 - .2539	6,0R-45	.236
.264	6,7R-45	.2756 - .2874	6,7R-45	.264
.287	7,3R-45	.2992 - .3070	7,3R-45	.287
.305	7,7R-45	.3150 - .3267	7,7R-45	.305
.344	8,7R-45	.3543 - .3661	8,7R-45	.344
.354	9,0-45	.3661 - .3818		
.382	9,7-45	.3937 - .4055	9,7R-45	.382
.394	10,0-45	.4055 - .4252		
.413	10,5-45	.4252 - .4448		
.433	11,0-45	.4449 - .4645		
.453	11,5-45	.4646 - .4881		
.472	12,0-45	.4882 - .5078	12,0R-45	.472
.492	12,5-45	.5079 - .5275		
.512	13,0-45	.5276 - .5472	13,0R-45	.512
.531	13,5-45	.5472 - .5669	13,5R-45	.531
.551	14,0-45	.5669 - .5866		
.571	14,5-45	.5866 - .6063		
.591	15,0-45	.6063 - .6259		
.610	15,5-45	.6260 - .6460	15,5R-45	.610
.630	16,0-45	.6460 - .6650		
.650	16,5-45	.6650 - .6850		
.669	17,0-45	.6850 - .7050	17,0R-45	.669
.689	17,5-45	.7050 - .7240	17,5R-45	.689
.709	18,0-45	.7240 - .7680	18,0R-45	.709
.748	19,0-45	.7680 - .8070	19,0R-45	.748
.780	19,8-45	.8000 - .8399	19,8R-45	.780
.819	20,8-45	.8400 - .8799	20,8R-45	.819
.858	21,8-45	.8800 - .9200	21,8R-45	.858
.906	23,0-45	.9201 - .9399	23,0R-45	.906
			23,4R-45	.921
.945	24,0-45	.9400 - 1.0049	24,0R-45	.945
.984	25,0-45	1.0050 - 1.0449	25,0R-45	.984
1.023	26,0-45	1.0450 - 1.1049	26,0R-45	1.023
			26,1R-45	1.028
1.063	27,0-45	1.1050 - 1.1399	27,0R-45	1.063
1.102	28,0-45	1.1400 - 1.1749	28,0R-45	1.102
1.142	29,0-45	1.1750 - 1.2199	29,0R-45	1.142
1.181	30,0-45	1.2200 - 1.2749	30,0R-45	1.181
1.220	31,0-45		31,0R-45	1.220
1.260	32,0-45	1.2750 - 1.3449	32,0R-45	1.260
			33,0R-45	1.299
1.339	34,0-45	1.3450 - 1.4299	34,0R-45	1.339
			35,4R-45	1.394
1.417	36,0-45	1.4300 - 1.4799	36,0R-45	1.417
1.455	37,0-45	1.4800 - 1.5199	37,0R-45	1.455
1.496	38,0-45		38,0R-45	1.496

Bearing dimensions: 75 mm OD x 16 mm wide x 45 mm bore

Quantity discounts for individual sizes only					
1-24	25-47	48-99	100+	Bearings	Snap Rings
\$10.00	\$9.50	\$8.50	\$8.00	\$30.00(6009-2RS)	\$.90 (DSH-45)

PRICING - US Dollars
45mm OD Bushing

75 mm OD SnapGuide®

INTERNATIONAL Drill Guide, INC. T 864.225.2214
F 864.226.0832
gundrill.com

[Click here to request free 75mm OD SnapGuide sample](#)

Bushing ID	Standard Part No.	Drill Range	Steadyrest Part No.	Bushing ID
1.496	38,0-75	1.5200 - 1.5709	38,0R-75	1.496
1.535	39,0-75	1.5710 - 1.6089	39,0R-75	1.535
1.575	40,0-75	1.6090 - 1.6499	40,0R-75	1.575
1.614	41,0-75	1.6500 - 1.6899	41,0R-75	1.614
1.654	42,0-75	1.6900 - 1.7289	42,0R-75	1.654
1.693	43,0-75	1.7290 - 1.7679	43,0R-75	1.693
1.732	44,0-75	1.7680 - 1.8069	44,0R-75	1.732
1.772	45,0-75	1.8070 - 1.8469	45,0R-75	1.772
1.811	46,0-75	1.8470 - 1.8859	46,0R-75	1.811
1.850	47,0-75	1.8860 - 1.9309	47,0R-75	1.850
1.890	48,0-75	1.9310 - 1.9799	48,0R-75	1.890
1.929	49,0-75	1.9800 - 2.0039	49,0R-75	1.929
1.969	50,0-75	2.0040 - 2.044	50,0R-75	1.969
2.011	51,1-75	2.0450+	51,1R-75	2.011
			56,0R-75	2.205
			62,0R-75	2.441

Bearing OD 115 mm x 20 mm wide x 75 mm bore

Quantity discounts for individual sizes only

1-24	25-47	48-99	100+	Bearings	Snap Rings
\$11.00	\$10.50	\$9.50	\$9.00	\$89.00 (6015-2RS)	\$1.55 DSH-75



Bushing for drills from 1.520" - 2.0450"+

PRICING US Dollars
75mm OD Bushing

2 FLUTE SnapGuide®

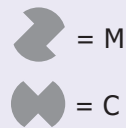

Appropriate
Drill
Sizes

Bushing ID	Bushing OD	Shape & Part #	Drill Diameter	Bearing Number	Bearing OD
.134	17mm	C 3,4-2-17	3.6mm	6003-2RS	35mm
.184	"	C 4,7-2-17	.203	"	"
.205	"	C 5,2-2-17	.212	"	"
.212	"	C 5,4-2-17	.219	"	"
.235	"	C 6,0-2-17	.250	"	"
.270	"	6,85-2-17	"	"	"
.407	"	M 10,35-2-17	.423	"	"
.476	"	C 12,1-2-17	.500	"	"
.265	"	C 6,7-2-20	7.0mm	6004-2RS	42mm
.368	"	9,35-2-20	"	"	"
.476	"	12,1-2-20	"	"	"
.489	"	C 12,4-2-20	.509	"	"
.332	30mm	M 8,4-2-30	.338	6006-2RS	55mm
.343	"	8,7-2-30	"	"	"
.347	"	M 8,81-2-30	.378	"	"
.350	"	C 8,9-2-30	.378	"	"
.378	"	9,6-2-30	"	"	"
.390	"	C 9,9-2-30	.394	"	"
.418	"	M 10,3-2-30	.437	"	"
.422	"	M 10,7-2-30	.433	"	"
.476	"	12,1-2-30	"	"	"
.653	"	M 16,6-2-30	.688	"	"
.740	"	M 18,88-2-30	.759	"	"
.748	"	M 19,0-2-30	.767	"	"
.764	"	19,4-2-30	"	"	"
.826	"	C 21,0-2-30	.854	"	"
.961	45mm	M 24,4-2-45	1.00	6009-2RS	75mm

INTERNATIONAL
Drill Guide, INC. T 864.225.2214
F 864.226.0832
gundrill.com

12

Click here to request free
2 Flute SnapGuide sample

Can't find the special bushing
you need? Let us quote it!



Quantity discounts for individual sizes only

Part Numbers	1-24	25-47	48-99	100+	Bearing #	Price Each
4,7-2-17 thru 12,1-2-17	\$5.75	\$5.25	\$4.25	\$3.25	6003-2RS	\$8.00
6,7-20 thru 12,4-2-20	\$6.75	\$5.50	\$4.50	\$3.50	6004-2RS	\$10.00
8,81-2-30 thru 19,0-2-30	\$7.75	\$6.50	\$6.00	\$5.50	6006-2RS	\$13.00
24,4-2-45	\$10.00	\$9.50	\$8.50	\$8.00	6009-2RS	\$30.00

PRICING - US Dollars
2 Flute SnapGuide®



SnapGuide®

Appropriate
Drill
Sizes

Bushing ID	Standard Part No.	Drill Range	Fits BTA Tube Dia.	Required Bearing	Bearing OD
.272	6,9R-30	.315 - .354	.280	6006-2RS	55mm (2.1653)
.321	8,15R-30	.355 - .393	.327	"	"
.350	8,9R-30	.394 - .432	.354	"	"
.390	9,9R-30	.433 - .472	.394	"	"
.429	10,9R-30	.473 - .535	.433	"	"
.468	11,9R-30	.536 - .575	.472	"	"
.508	12,9R-30	.576 - .614	.512	"	"
.547	13,9R-30	.615 - .657	.551	"	"
.587	14,9R-30	.658 - .696	.591	"	"
.626	15,9R-30	.697 - .744	.630	"	"
.665	16,9R-30	.745 - .787	.669	"	"
.705	17,9R-30	.788 - .858	.709	"	"
.783	19,9R-30	.859 - .948	.787	"	"
.862	21,9R-30	.949 - 1.039	.866	"	"
.945	24,0R-30	1.040 - 1.129	.945	"	"
1.024	26,0R-45	1.130 - 1.220	1.024	6009-2RS	75mm (2.9528)
1.102	28,0R-45	1.221 - 1.311	1.102	"	"
1.181	30,0R-45	1.312 - 1.425	1.181	"	"
1.299	33,0R-45	1.426 - 1.559	1.299	"	"
1.417	36,0R-45	1.560 - 1.692	1.417	"	"
1.535	39,0R-75	1.693 - 1.850	1.535	6015-2RS	115mm (4.5276)
1.693	43,0R-75	1.851 - 2.035	1.693	"	"
1.850	47,0R-75	2.036 - 2.212	1.850	"	"
2.008	51,0R-75	2.213 - 2.559	2.008	"	"
2.205	56,0R-75	2.560 - 2.637	2.205	"	"
2.441	62,0R-75	2.638 - 2.873	2.441	"	"

BTA

SnapGuide®

INTERNATIONAL
Drill Guide, INC.T 864.225.2214
F 864.226.0832

gundrill.com

Click here to request free
BTA SnapGuide sample

13

Quantity discounts for individual sizes only

Part Numbers	1-24	25-47	48-99	100+	Bearing #	Price Each	Snap Ring
6,9R-30 thru 24,0R-30	\$7.75	\$6.50	\$6.00	\$5.50	6006-2RS	\$13.00	\$.25 DSH-30
26,0R-45 thru 36,0R-45	\$10.00	\$9.50	\$8.50	\$8.00	6009-2RS	\$30.00	\$.90 DSH-45
39,0R-75 thru 62,0R-75	\$11.00	\$10.50	\$9.50	\$9.00	6015-2RS	\$89.00	\$1.55 DSH-75

PRICING
US Dollars
BTA Bushings

The color blue is a registered trademark of International Drill Guide, Inc.

BTA bushings are round hole bushings designed to be used on the steadyrest of BTA drilling machines. They support the drill tube with a slight compression fit and help limit vibration.



About Drill Guides

Flexible plastic Drill Guide bushings stop drill whipping and seal the chip box by stretching over the carbide drill tip and contracting onto the steel drill body. They are typically mounted in a bearing and rotate with the drill. This is our first and oldest product and is still used by many customers to maximize penetration rates, accuracy, and stop vibration. These bushings perform the same function as our SnapGuide®. Our signature **Blue Bushings®** guarantee you top quality.

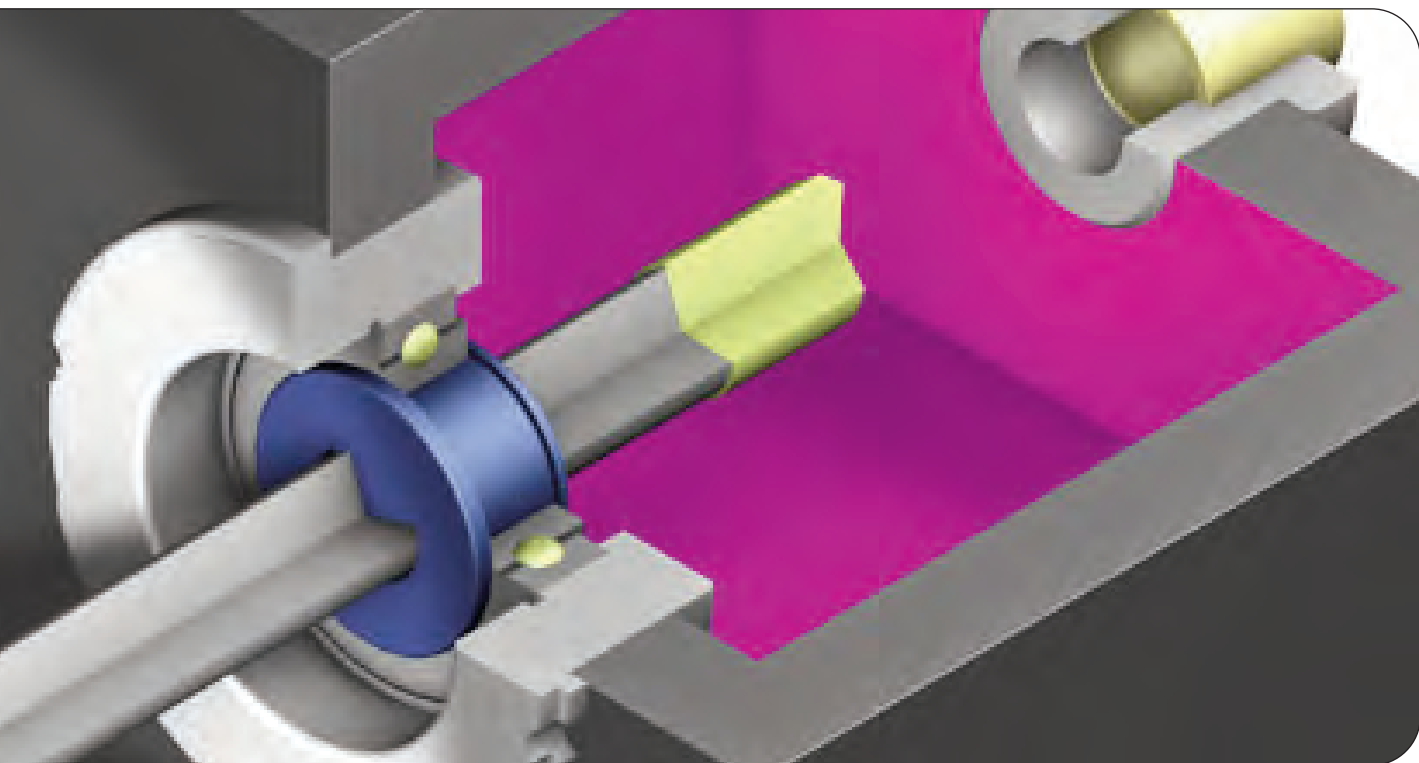
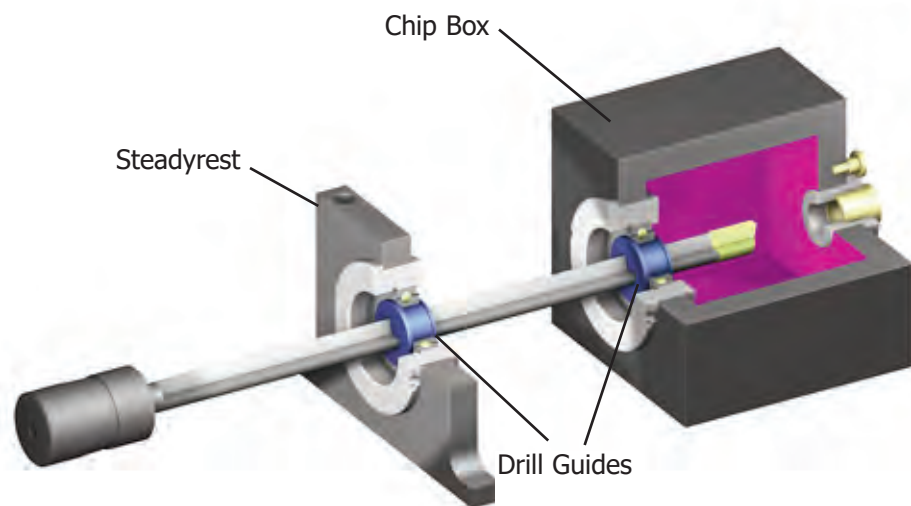



Appropriate
Drill
Sizes

Bushing ID	Drill Guide Part No.	Drill Range	Bearing ID	Bearing OD
.070	A100	<=.0831	.315	.9449
.080	A110	.0832 - .0933	"	"
.090	A120	.0934 - .1035	"	"
.105	A130	.1036 - .1200	"	"
.120	A140	.1201 - .1329	"	"
.130	A150	.1330 - .1459	"	"
.140	A160	.1460 - .1561	"	"
.156	A170	.1562 - .1823	"	"
.171	A180	.1824 - .1949	"	"
.187	A190	.1950 - .2099	"	"
	A192			
.187	B090	.1950 - .2099		
.203	B100	.2100 - .2289	.590	1.3780
.219	B110	.2290 - .2499	"	"
.237	B120	.2500 - .2649	"	"
.250	B130	.2650 - .2799	"	"
.263	B140	.2800 - .2949	"	"
.281	B150	.2950 - .3079	"	"
.298	B160	.3080 - .3299	"	"
.314	B170	.3300 - .3399	"	"
.328	B174	.3400 - .3599	"	"
.343	B180	.3600 - .3699	"	"
.357	B190	.3700 - .3799	"	"
.375	B200	.3800 - .4059	"	"
.390	B210	.4060 - .4249	"	"
.250	C020		"	"
.357	C1401		"	"
.406	C100	.4250 - .4479	.787	1.8504
.429	C110	.4480 - .4629	"	"
.437	C120	.4630 - .4779	"	"
.453	C130	.4780 - .4909	"	"
.468	C140	.4910 - .5099	"	"
.484	C150	.5100 - .5249	"	"
.500	C160	.5250 - .5399	"	"
.509	C170	.5400 - .5549	"	"
.531	C180	.5550 - .5649	"	"
.546	C190	.5650 - .5799	"	"
.562	C200	.5800 - .5999	"	"
.466	D030	.4910 - .5099	.984	2.0472
.482	D050	.5100 - .5249	"	"
.510	D070	.5400 - .5549	"	"
.578	D100	.6000 - .6199	"	"
.593	D110	.6200 - .6399	"	"
.609	D120	.6400 - .6599	"	"
.625	D130	.6600 - .6799	"	"
.640	D140		"	"
.656	D150	.6800 - .6999	"	"
.671	D160	.7000 - .7199	"	"
.687	D170		"	"
.703	D180	.7200 - .7399	"	"
.718	D190	.7400 - .7599	"	"
.546	E050	.5650 - .5799		
.562	E070	.5800 - .5999		
.703	E090	.7200 - .7399	1.378	2.8346
.718	E100	.7400 - .7599	"	"
.734	E110	.7600 - .7799	"	"
.750	E120	.7800 - .7899	"	"
.765	E130	.7900 - .7999	"	"
.781	E140	.8000 - .8199	"	"
.796	E150	.8200 - .8399	"	"
.812	E160	.8400 - .8599	"	"

Continued on next page

Drill Guide Parts

INTERNATIONAL
Drill Guide, INC.
 T 864.225.2214
 F 864.226.0832
 gundrill.com

[Click here to request free Drill Guide sample](#)

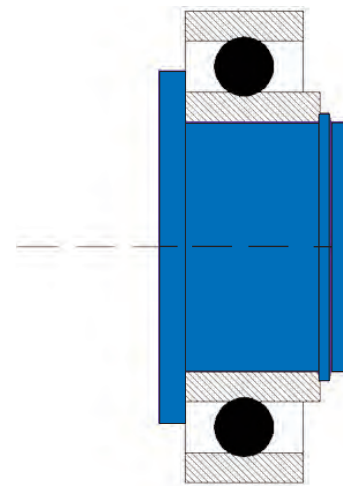

NOTE
 Drill Guides are also available in a softer material by placing an "S" at the end of the part # example A100S

Drill Guide Parts

CONTINUED

INTERNATIONAL Drill Guide, INC. T 864.225.2214
F 864.226.0832
gundrill.com

Click here to request free Drill Guide sample

16

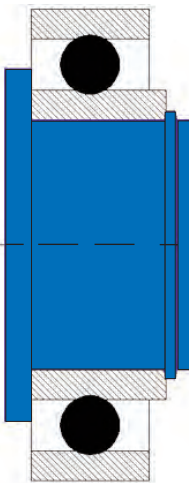

Bushing ID

Drill Guide Part No.

Appropriate Drill Sizes

Drill Range

Bearing ID

Bearing OD

.828	E170	.8600 - .8699	1.378	2.8346
.843	E180	.8700 - .8799	"	"
.859	E190	.8800 - .9199	"	"
.875	E200		"	"
.890	E210	.9200 - .9399	"	"
.906	E220		"	"
.921	E230	.9400 - .9599	"	"
.937	E240	.9600 - .9699	"	"
.953	E250	.9700 - .9799	"	"
.968	E260	.9800 - 1.0449	"	"
1.008	E280	1.0450 - 1.1049	"	"
1.073	E290	1.1050 - 1.1699	"	"
1.138	E300	1.1700 - 1.2190	"	"
1.183	E310	1.2200 - 1.2500	"	"
.965	F100	.9800 - 1.0049	1.772	3.3465
.988	F104	1.0050 - 1.0449	"	"
1.005	F110	1.0450 - 1.1049	"	"
1.028	F114		"	"
1.065	F120	1.1050 - 1.1699	"	"
1.135	F130	1.1700 - 1.1999	"	"
1.145	F134	1.2000 - 1.2349	"	"
1.180	F140	1.2350 - 1.2599	"	"
1.235	F150	1.2600 - 1.2999	"	"
1.275	F160	1.3000 - 1.3409	"	"
1.305	F170	1.3410 - 1.3990	"	"
1.335	F180	1.4000 - 1.4439	"	"
1.346	F356		"	"
1.378	F363		"	"
1.365	G090		2.165	3.9370
1.400	G100	1.4440 - 1.4949	"	"
1.440	G110	1.4950 - 1.5032	"	"
1.475	G120	1.5030 - 1.5699	"	"
1.545	G130	1.5700 - 1.6899	"	"
1.665	G140	1.6900 - 1.7599	"	"
1.720	H100	1.7600 - 1.8209	2.559	4.7244
1.805	H110	1.8210 - 1.9309	"	"
1.925	H120	1.9310 - 2.0000	"	"
2.035	H130		"	"
2.180	H140		"	"

PRICING - US Dollars
Drill Guide Parts

NOTE

Drill Guides are also available in a softer material by placing an "S" at the end of the part # example A100S

Quantity discounts for individual sizes only

Part #	1-9	10-24	25-47	48-99	100+	Bearing #	Price Each
A100-A190	\$8.25	\$6.75	\$5.00	\$4.00	\$3.00	87008	\$14.00
B100-B210	\$8.25	\$6.75	\$5.25	\$4.25	\$3.25	87502	\$14.00
C100-C200	\$8.50	\$7.00	\$5.50	\$4.50	\$3.50	87504	\$20.00
D030-D190	\$8.75	\$7.75	\$6.50	\$6.00	\$5.50	87505	\$22.00
E090-E310	\$9.00	\$8.00	\$7.50	\$6.50	\$6.00	87507	\$34.00
F100-F363	\$10.50	\$9.75	\$8.75	\$8.25	\$7.75	87509	\$46.00
G090-G140	\$11.50	\$10.75	\$9.75	\$9.25	\$8.75	6211-2RS	\$55.00
H100-H140	\$12.50	\$11.75	\$10.75	\$10.50	\$9.75	6213-2RS	\$71.00

"G" and "H" series parts also available to fit old style 211KLD and 213KLD. Call for details.

Drill Guide Parts

Two Flute & Special Bushings



INTERNATIONAL
Drill Guide, INC.
T 864.225.2214
F 864.226.0832
gundrill.com

Can't find the special bushing you need? Let us quote it!

[Click here to request free Drill Guide sample](#)

Bushing ID & Shape	Drill Guide Part No.	Drill Diameter	Bearing ID	Bearing OD
.057 R	R057	.0600 - .0649	.3150	.9449
.072 R	R072	.0760 - .0831		
.076 R	R076	.0832 - .0882		
.080 R	R080	.0883 - .0933		
.083 R	R083			
.087 R	R087	.0934 - .0984		
.091 R	R091	.0985 - .1035		
.095 R	R095	.1036 - .1086		
.100 R	R100	.1087 - .1137		
.105 R	R105	.1138 - .1179		
.110 R	R110	.1180 - .1239		
.115 R	R115			
.119 R	R119	.1240 - .1279		
.134 R	R134	.1410 - .1459		
.169 R	R169	.1719 - .1875		
.192 R	R192			
.167 C	A185	.1875		
.177 R	R177			
.187 R	R187		.5900	1.3780
.218 R	R218	.2290 - .2399		
.230 R	R230	.2450 - .2499		
.235 R	R235			
.239 R	R239	.2500 - .2599		
.218 M	B115	.2500		
.260 C	B123	.2810		
.251 M	B135	.2810		
.260 M	B137	.2810		
.290 C	B145	.3120		
.280 M	B155	.3120		
.285 C	B157	.3120		
.312 M	B175	.3440		
.343 M	B195	.3750		
.348 C	B197	.3750		
.374 M	B215	.4060		
.375 C	B217	.3940		
.378 C	C095	10.2000	.7874	1.8504
.385 M	C103	.4170		
.405 M	C105	.4370		
.412 R	R412			
.437 M	C125	.4680		
.468 M	C145	.5000		

Continued on page 18

Note: More round hole bushings on page 19 under BTA Drill Guides

Drill Guide Parts

Two Flute & Special Bushings

CONTINUED

INTERNATIONAL
Drill Guide, INC. T 864.225.2214
F 864.226.0832
gundrill.com

Click here to request free
Drill Guide sample

18

PRICING - US Dollars
Drill Guide Parts
Two Flute &
Special Bushings

Can't find the special bushing
you need? Let us quote it!

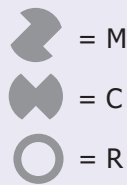

Bushing ID & Shape	Drill Guide Part No.	Drill Diameter	Bearing ID	Bearing OD
.500 M	C165	.5310		
.530 M	C185	.5620		
.550 M	C195	.5830		
.562 M	C205	.5930		
.585 M	D115	.6250	.9843	2.0472
.615 M	D135	.6560		
.645 M	D155	.6870		
.665 M	D165	.6970		
.680 M	D175	.7180		
.710 M	D185	.7500		
.772 M	E103	.8120	1.3780	2.8346
.775 C	E104	.8120		
.767 M	E105	.7870		
.925 M	E235	.9450		
1.005 M	E295	1.0750		
1.150 M	E305	1.1810		
1.649 M	H095			
1.800 M	H097			
1.860 M	H115			
1.948 M	H125			
2.010 M	H135			

Note: More round hole bushings on page 19 under BTA Drill Guides

Quantity discounts for individual sizes only

Part #	1-9	10-24	25-47	48-99	100+	Bearing #	Price Each
A185	\$8.25	\$6.75	\$5.00	\$4.00	\$3.00	87008	\$14.00
B115-B215	\$8.25	\$6.75	\$5.25	\$4.25	\$3.25	87502	\$14.00
C103-C205	\$8.50	\$7.00	\$5.50	\$4.50	\$3.50	87504	\$20.00
D115-D185	\$8.75	\$7.75	\$6.50	\$6.00	\$5.50	87505	\$22.00
E103-E305	\$9.00	\$8.00	\$7.50	\$6.50	\$6.00	87507	\$34.00
R057-R169	\$8.25	\$6.75	\$5.00	\$4.00	\$3.00	87008	\$14.00
R230-R239	\$8.25	\$6.75	\$5.27	\$4.25	\$3.25	87502	\$14.00



BTA

Drill Guides

INTERNATIONAL
Drill Guide, INC. T 864.225.2214
F 864.226.0832
gundrill.com

[Click here to request free
Drill Guide sample](#)

19

PRICING - US Dollars
BTA Bushings



Bushing ID	Standard Part No.	Appropriate Drill Sizes Drill Range	Fits BTA Tube Dia.	Required Bearing	Bearing OD
.276	R276	.315 - .354	.280	87502	1.3780
.323	R323	.355 - .393	.327	"	"
.350	R350	.394 - .432	.354	"	"
.390	R390	.433 - .472	.394	"	"
.429	R429	.473 - .535	.433	87504	1.8504
.468	R468	.536 - .575	.472	"	"
.508	R508	.576 - .614	.512	"	"
.547	R547	.615 - .657	.551	"	"
.587	R587	.658 - .696	.591	87505	2.0472
.626	R626	.697 - .744	.630	"	"
.666	R666	.745 - .787	.670	"	"
.705	R705	.788 - .858	.709	"	"
.783	R783	.859 - .948	.787	87507	2.8436
.862	R862	.949 - 1.039	.866	"	"
.941	R941	1.040 - 1.129	.945	"	"
1.020	R1020	1.130 - 1.220	1.024	87509	3.3465
1.098	R1098	1.221 - 1.311	1.102	"	"
1.177	R1177	1.312 - 1.425	1.181	"	"
1.295	R1295	1.426 - 1.559	1.299	"	"
1.413	R1413	1.560 - 1.692	1.417	6211-2RS	3.9370
1.531	R1531	1.693 - 1.850	1.535	"	"
1.689	R1689	1.851 - 2.035	1.693	"	"
1.846	R1846	2.036 - 2.212	1.850	6213-2RS	4.7244
2.004	R2004	2.213 - 2.559	2.008	"	"
2.201	R2201	2.560 - 2.637	2.205	"	"
2.437	R2437	2.638 - 2.873	2.441	"	"

Quantity - Quantity discounts for individual sizes only

Part #	1-9	10-24	25-47	48-99	100+	Bearing #	Price Each
R276-R390	\$8.25	\$6.75	\$5.25	\$4.25	\$3.25	87502	\$14.00
R429-R547	\$8.50	\$7.00	\$5.50	\$4.50	\$3.50	87504	\$20.00
R587-R705	\$8.75	\$7.75	\$6.50	\$6.00	\$5.50	87505	\$22.00
R783-R941	\$9.00	\$8.00	\$7.50	\$6.50	\$6.00	87507	\$34.00
R1020-R1413	\$10.50	\$9.75	\$8.75	\$8.25	\$7.75	87509	\$46.00
R1531-R1689	\$11.50	\$10.75\$	\$9.75	\$9.25	\$8.75	6211-2RS	\$55.00
R1846-R2437	\$12.50	11.75	\$10.75	\$10.50	\$9.75	6213-2RS	\$71.00

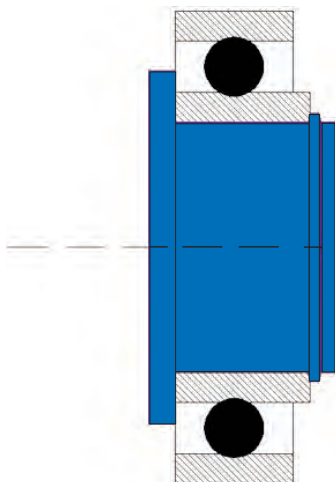

The color blue is a registered trademark of International Drill Guide, Inc.



BTA bushings are round hole bushings designed to be used on the steadyrest of BTA drilling machines. They support the drill tube with a slight compression fit and help limit vibration.

Chip Deflectors

Chip Deflectors stop metal chips and cutting oil from exiting the back of the chip box. They provide sealing only and no drill support. They are used on gun drill machines on short rigid drills when whipping is not a problem. They are also used in front of a Drill Guide or a SnapGuide® to extend bushing and bearing life. Chip Deflectors feature a hardened steel face bonded to a flexible polymer backing to provide perfect sealing on the drill and long life.

20

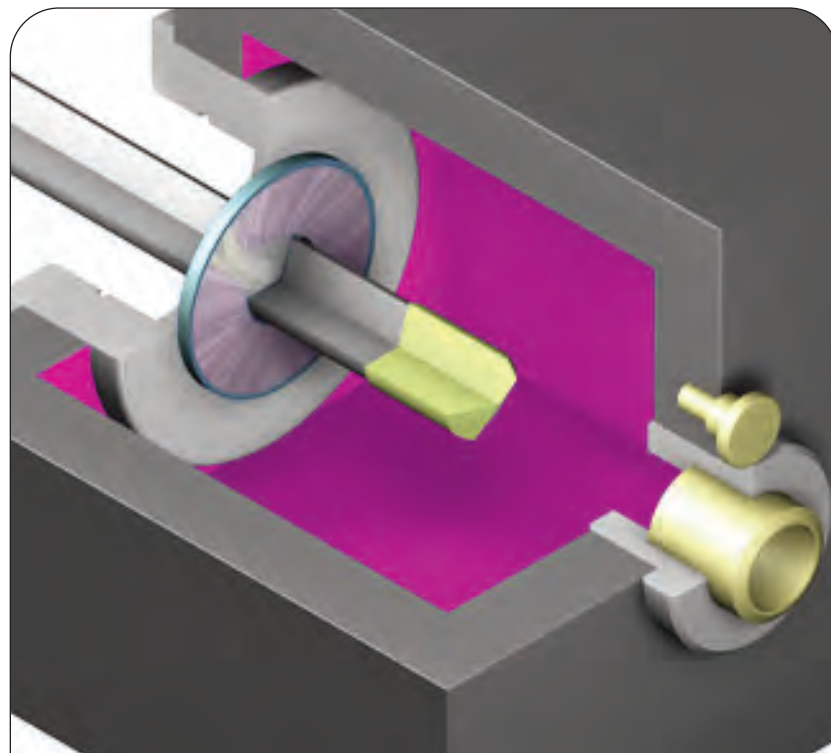
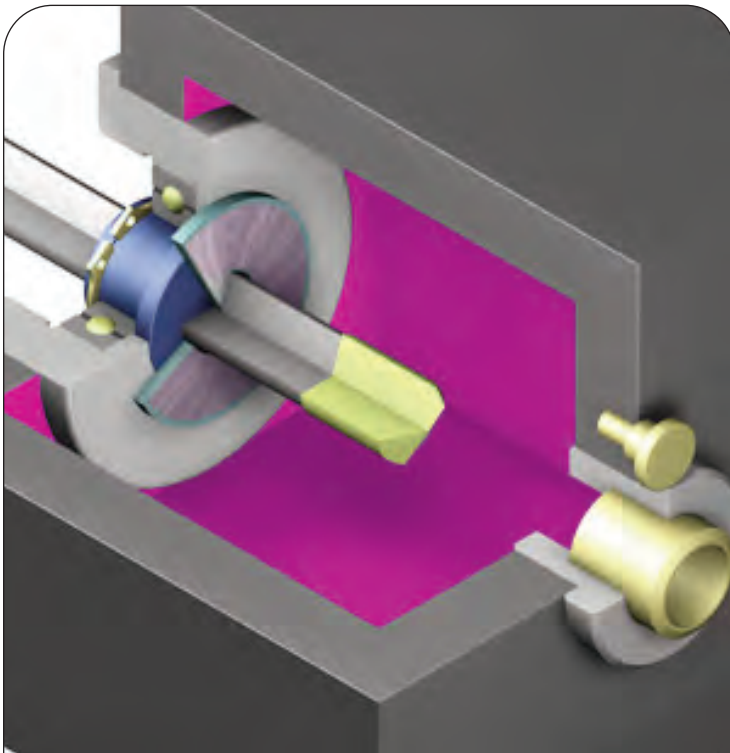

Appropriate
Drill
Sizes

Appropriate
Drill
Sizes

Appropriate
Drill
Sizes

Part #	Drill Range	Part #	Drill Range	Part #	Drill Range
070	.0781 - .0831	315	.3300 - .3399	960	.9800 - 1.0049
075	.0832 - .0882	325	.3400 - .3499	980	1.0050 - 1.0449
080	.0883 - .0933	335	.3500 - .3599	1020	1.0450 - 1.1049
085	.0934 - .0984	345	.3600 - .3699	1080	1.1050 - 1.1749
090	.0985 - .1035	355	.3700 - .3799	1150	1.1750 - 1.2199
095	.1036 - .1086	365	.3800 - .3879	1195	1.2200 - 1.2749
100	.1087 - .1137	370	.3880 - .3929	1250	1.2750 - 1.3449
105	.1138 - .1188	375	.3930 - .4029	1320	1.3450 - 1.4799
110	.1189 - .1239	385	.4030 - .4179	1455	1.4800 - 1.5849
115	.1240 - .1295	400	.4180 - .4279	1560	1.5850 - 1.7049
120	.1296 - .1350	410	.4280 - .4329	1680	1.7050 - 1.8449
125	.1351 - .1405	415	.4330 - .4379	1820	1.8450 - 1.9649
130	.1406 - .1458	420	.4380 - .4479	1940	1.9650 - 2.0000
135	.1459 - .1510	430	.4480 - .4629		
140	.1511 - .1561	445	.4630 - .4779		
145	.1562 - .1614	460	.4780 - .4949		
150	.1615 - .1666	475	.4950 - .5099		
155	.1667 - .1718	490	.5100 - .5249		
160	.1719 - .1771	505	.5250 - .5399		
165	.1772 - .1823	520	.5400 - .5549		
170	.1824 - .1874	535	.5550 - .5649		
175	.1875 - .1949	545	.5650 - .5799		
180	.1950 - .1999	560	.5800 - .5899		
185	.2000 - .2049	570	.5900 - .5999		
190	.2050 - .2099	580	.6000 - .6199		
195	.2100 - .2149	600	.6200 - .6399		
200	.2150 - .2199	620	.6400 - .6499		
205	.2200 - .2249	630	.6500 - .6599		
210	.2250 - .2299	640	.6600 - .6799		
215	.2300 - .2349	660	.6800 - .6999		
220	.2350 - .2399	680	.7000 - .7199		
225	.2400 - .2449	700	.7200 - .7399		
230	.2450 - .2499	720	.7400 - .7599		
235	.2500 - .2549	740	.7600 - .7799		
240	.2550 - .2599	760	.7800 - .7999		
245	.2600 - .2649	780	.8000 - .8199		
250	.2650 - .2699	800	.8200 - .8399		
255	.2700 - .2799	820	.8400 - .8599		
265	.2800 - .2899	840	.8600 - .8799		
275	.2900 - .2949	860	.8800 - .8999		
280	.2950 - .2999	880	.9000 - .9199		
285	.3000 - .3099	900	.9200 - .9399		
295	.3100 - .3199	920	.9400 - .9599		
305	.3200 - .3299	940	.9600 - .9799		

Chip Deflectors

INTERNATIONAL Drill Guide, INC. T 864.225.2214 F 864.226.0832 gundrill.com



.970 for drills .070-2199
1.46 for drills .220-.427
2.06 for drills .428-.759
2.86 for drills .760-2.00

Click here to request free Chip Deflector sample



Quantity discounts for individual sizes only

Part #	Pricing	Discounts
070-110	\$4.50 each	10% off 100 or more any one size
115-235	\$4.00 each	10% off 100 or more any one size
240-355	\$5.00 each	10% off 100 or more any one size
365-600	\$6.00 each	10% off 100 or more any one size
620-720	\$7.00 each	10% off 100 or more any one size
740-1195	\$8.00 each	10% off 100 or more any one size
1250-1680	\$10.00 each	10% off 100 or more any one size
1820-1940	\$12.00 each	10% off 100 or more any one size

PRICING - US Dollars
Chip Deflectors

32mm & 40mm OD Chip Deflectors

INTERNATIONAL
Drill Guide, INC. T 864.225.2214
F 864.226.0832
gundrill.com

Appropriate Drill Sizes		Appropriate Drill Sizes		Appropriate Drill Sizes	
Part #	Drill Range	Part #	Drill Range	Part #	Drill Range
32-4,85	5.00 - 5.249	32-8,4	8.70 - 8.999	32-13,65	13.95 - 14.449
32-5,05	5.25 - 5.449	32-8,7	9.00 - 9.299	32-14,15	14.45 - 14.949
32-5,25	5.45 - 5.649	32-9,0	9.30 - 9.699	32-14,65	14.95 - 15.559
32-5,45	5.65 - 5.849	32-9,4	9.70 - 9.999	40-15,2	15.60 - 16.399
32-5,65	5.85 - 5.999	32-9,7	10.00 - 10.299	40-16,0	16.40 - 17.199
32-5,85	6.00 - 6.299	32-10,0	10.30 - 10.599	40-16,8	17.20 - 17.999
32-6,05	6.30 - 6.499	32-10,3	10.60 - 10.999	40-17,6	18.00 - 18.799
32-6,25	6.50 - 6.799	32-10,7	11.00 - 11.399	40-18,4	18.80 - 19.799
32-6,55	6.80 - 7.099	32-11,1	11.40 - 11.699	40-19,3	19.80 - 20.799
32-6,85	7.10 - 7.399	32-11,4	11.70 - 12.099	40-20,3	20.80 - 21.799
32-7,15	7.40 - 7.699	32-11,8	12.10 - 12.449	40-21,3	21.80 - 22.790
32-7,45	7.70 - 7.999	32-12,15	12.45 - 12.949	40-22,3	22.80 - 23.790
32-7,75	8.00 - 8.299	32-12,65	12.95 - 13.449	40-23,3	23.80 - 24.799
32-8,05	8.30 - 8.699	32-13,15	13.45 - 13.949	40-24,3	24.80 - 25.999

[Click here to request free Chip Deflector sample](#)

22

NOTE

These Chip Deflectors have smaller outside diameters than standard Chip Deflectors. They are designed for non U.S. made gun drill machines that require smaller outside diameters due to the chip box and bearing housing design. Order this style of Chip Deflector only if your machine requires it.

32mm OD Chip Deflectors also available for drill diameters 15.6mm -25.999mm. 40mm OD Chip Deflectors also available for drill diameters under 15.6 mm. Contact us for a quotation.



Standard Design - Solid Plastic	Optional Steel Face on Both Sides
	<p>32mm x 11mm wide or 40mm x 12mm wide Contact for price and delivery</p>

Quantity discounts for individual sizes only

PRICING - US Dollars Chip Deflectors

Part #	Pricing	Discounts
32-4,85 thru 32-6,0	\$4.00 each	10% off 100 pieces or more of any one size
32-6,05 thru 32-14,95	\$5.00 each	10% off 100 pieces or more of any one size
40-15,25 thru 40-24,3	\$6.00 each	10% off 100 pieces or more of any one size

Small Diameter Bushings

SnapGuide®



INTERNATIONAL
Drill Guide, INC. gundrill.com
T 864.225.2214
F 864.226.0832

[Click here to request free Special Size SnapGuide sample](#)

NOTE

Contour hole bushings in these ranges may contribute to premature drill breakage. Use these bushings at your own risk. Call us for contour bushings in this range and we will review your application.

PRICING - US Dollars
Small Diameter Bushings

Small Diameter 17mm OD SnapGuide Bushings with Contour Hole

Bushing ID	Standard Part No.	Drill Range
.079	2,0-17	.0883 - .0933
.113	2,87-17	.1180 - .1239
.121	3,07-17	.1240 - .1329
.129	3,27-17	.1330 - .1369
.133	3,37-17	.1370 - .1430
.140	3,55-17	.1431 - .1519

Quantity discounts for individual sizes only

1-24	25-47	48-99	100+	Bearings	Snap Rings
\$5.75	\$5.25	\$4.25	\$3.25	\$8.00 (6003-2RS)	\$.25 (DSH-17)

Small Diameter 20mm OD SnapGuide Bushings with Contour Hole

Bushing ID	Standard Part No.	Drill Range
.089	2,27-20	.0985 - .1010
.105	2,67-20	.1138 - .1179
.121	3,07-20	.1240 - .1329
.129	3,27-20	.1330 - .1430
.152	3,87-20	.1520 - .1609

Quantity discounts for individual sizes only

1-24	25-47	48-99	100+	Bearings	Snap Rings
\$6.75	\$5.50	\$4.50	\$3.50	\$10.00 (6004-2RS)	\$.25 (DSH-20)

Small Diameter 30mm OD SnapGuide Bushings with Contour Hole

Bushing ID	Standard Part No.	Drill Range
.105	2,67-30	.1036 - .1179
.113	2,87-30	.1180 - .1239
.121	3,07-30	.1240 - .1329
.129	3,27-30	.1330 - .1369
.133	3,37-30	.1370 - .1430
.140	3,55-30	.1431 - .1519
.152	3,87-30	.1520 - .1609
.168	4,27-30	.1667 - .1718
.176	4,47-30	.1719 - .1823
.177	4,50-30	
.184	4,67-30	.1824 - .1949
.192	4,87-30	.1950 - .2049

Quantity discounts for individual sizes only

1-24	25-47	48-99	100+	Bearings	Snap Rings
\$775	\$6.50	\$6.00	\$5.50	\$13.00 (6006-2RS)	\$.25 (DSH-30)

15mm OD SnapGuide®

INTERNATIONAL Drill Guide, INC. T 864.225.2214 F 864.226.0832 gundrill.com

[Click here to request free sample](#)

PRICING - US Dollars
15 mm OD SnapGuide®

24

Extra Wide Drill Guides

Can't find the special bushing you need? Let us quote it!

[Click here to request free sample](#)

PRICING - US Dollars
Extra Wide Drill Guide

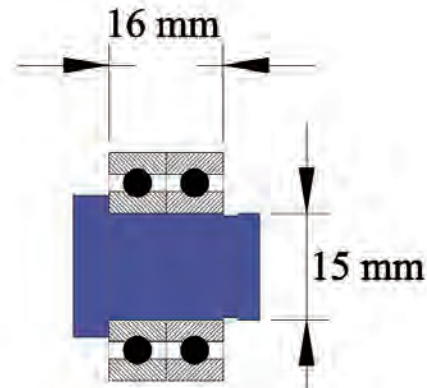

Bushing ID	Steadyrest Part No.	Appropriate Drill Sizes
.226	5,75R-15	
.236	6,0R-15	

Quantity discounts for individual sizes only

1-24	25-47	48-99	100+	Bearings (16002)
\$7.75	\$6.50	\$6.00	\$5.50	

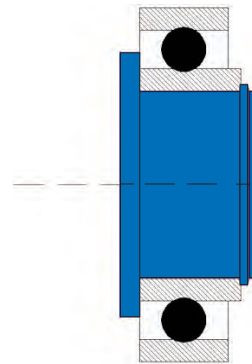

Bushing ID	Drill Guide Part No.	Appropriate Drill Sizes	Bearing ID	Bearing OD	Bearing Width
1.480	G400S		2.165	3.9370	1.063
1.550	G412S		"	"	
1.721	H460S		2.559	4.7244	1.220
1.806	H480S		"	"	
1.879	H490S		"	"	
1.922	H510S		"	"	

Quantity discounts for individual sizes only

Part #	1-9	10-24	25-47	48-99	100+	Bearing #	Price Each
G400S - G412S	\$11.50	\$10.75	\$9.75	\$9.25	\$8.75	8511	
H460S - H510S	\$12.50	\$11.75	\$10.75	\$10.50	\$9.75	8513	



Bushing ID

Part No.

Appropriate Drill Sizes

Drill Diameter

Bearing ID

Bearing OD

.437	S11,1-17	.4527	17	35
.509	S509-20		20	42
.540	S540-20			
.603	S603-20			
.548	S548-30		30	55
.555	S555-30			
.598	S598-30			
.605	S605-30	.623		
.688	S688-30	.718		
.748	S748-30			
.787	S787-30			
.850	S850-30			
.875	S875-30	.9375		
.888	S888-30	.908		
.908	S908-30			
.978	S978-45	1.000	45	75
1.134	S1134-45			
1.224	S1224-45			
1.246	S1246-45			

Quantity discounts for individual sizes only

Part #	1-24	25-47	48-99	100+	Bearing #	Price Each
S11,1-17	\$5.75	\$5.25	\$4.25	\$3.25	6003-2RS	\$8.00
S509-20 thru S603-20	\$6.75	\$5.50	\$4.50	\$3.50	6004-2RS	\$10.00
S548-30 thru S908-30	\$7.75	\$6.50	\$6.00	\$5.50	6006-2RS	\$13.00
S978-45 thru S1246-45	\$10.00	\$9.50	\$8.50	\$8.00	6009-2RS	\$30.00



Bushing ID

Part No.

Appropriate Drill Sizes

Drill Diameter

Bearing ID

Bearing OD

.378	B378S	.3937	.590	1.378
.378	C378S	.3937	.787	1.8504
.378	C393C	.3937		
	C463			
.488	C488S			
.595	D595S		.984	2.0472
.628	D628S			
.688	D688S	.709		
.711	D711			
.766	E766S			
.918	E918			2.8346
1.139	F1139S	1.156		
1.446	G1446			
1.671	G1671			

Quantity discounts for individual sizes only

Part #	1-9	10-24	25-47	48-99	100+	Bearing #	Price Each
B378S	\$8.25	\$6.75	\$5.00	\$4.00	\$3.00	87008	\$14.00
C378S - C488S	\$8.25	\$6.75	\$5.25	\$4.25	\$3.25	87502	\$14.00
D595S - D711	\$8.50	\$7.00	\$5.50	\$4.50	\$3.50	87504	\$20.00
D115 - D185	\$8.75	\$7.75	\$6.50	\$6.00	\$5.50	87505	\$22.00
E766S - E918	\$9.00	\$8.00	\$7.50	\$6.50	\$6.00	87507	\$34.00
F1139S	\$8.25	\$6.75	\$5.00	\$4.00	\$3.00	87008	\$14.00
G1446 - G1671	\$11.50	\$10.75	\$9.75	\$9.25	\$8.75	6211-2RS	\$55.00

SnapGuides[®] for Allied Drills



INTERNATIONAL
Drill Guide, INC.

T 864.225.2214
F 864.226.0832
gundrill.com

[Click here to request free sample](#)

PRICING - US Dollars
SnapGuides[®] for Allied Drills

25

Drill Guides for Allied Drills

[Click here to request free sample](#)

PRICING - US Dollars
Drill Guides for Allied Drills

SnapGuide® Bushings for SUMOGUN Drills

INTERNATIONAL
Drill Guide, INC. T 864.225.2214
F 864.226.0832
gundrill.com

26



The color blue is a registered trademark of International Drill Guide, Inc.

Steadyrest

SnapGuide® use on every gun drill machine.

Copyright © 2017
by International Drill Guide, Inc.

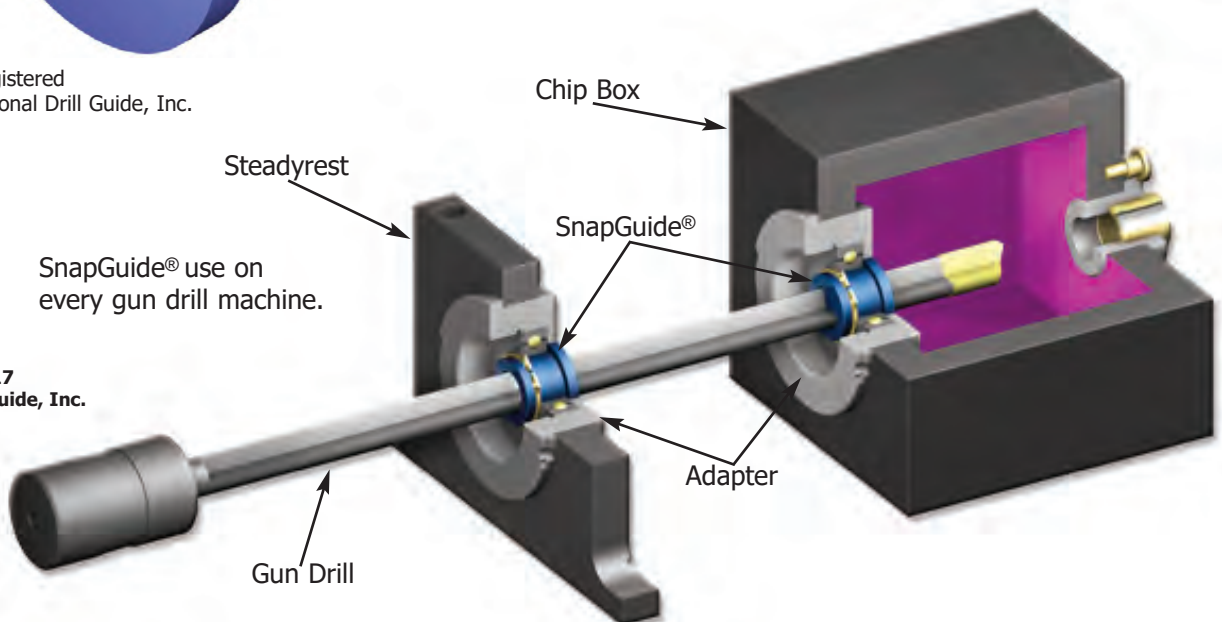

See our complete line of support bushings and seals for all deep hole tools at www.gundrill.com.

6006-2RS
Bearing*

Appropriate
Drill
Sizes

6206-2RS
Bearing**

SnapGuide®

SnapGuide®

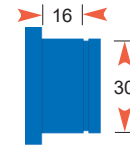
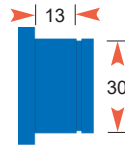

Drill Range
(Inches)

SI9,6-30	.3937 - .4133	LSI9,6-30
SI10,1-30	.4134 - .4330	LSI10,1-30
SI10,6-30	.4331 - .4527	LSI10,6-30
SI11,1-30	.4528 - .4723	LSI11,1-30
SI11,6-30	.4724 - .4920	LSI11,6-30
SI12,1-30	.4921 - .5117	LSI12,1-30
SI12,6-30	.5118 - .5314	LSI12,6-30
SI13,1-30	.5315 - .5511	LSI13,1-30
SI13,6-30	.5512 - .5708	LSI13,6-30
SI14,1-30	.5709 - .5905	LSI14,1-30
SI14,6-30	.5906 - .6298	LSI14,6-30
SI15,4-30	.6299 - .6692	LSI15,4-30
SI16,4-30	.6693 - .7086	LSI16,4-30
SI17,4-30	.7087 - .7479	LSI17,4-30
SI18,4-30	.7480 - .7873	LSI18,4-30
SI19,4-30	.7874 - .8267	LSI19,4-30
SI20,4-30	.8268 - .8660	LSI20,4-30
SI21,4-30	.8661 - .9054	LSI21,4-30
SI22,4-30	.9055 - .9448	LSI22,4-30
SI23,4-30	.9449 - .9842	LSI23,4-30
SI24,5-30	.9843 - 1.0232	LSI24,5-30

[Click here to request free sample](#)

Bearing 6006-2RS* dimensions 55 mm OD X 30 mm ID X 13 mm wide
Bearing 6206-2RS** dimensions 62 mm OD X 30 mm ID X 16 mm wide

Quantity discounts for individual sizes only

PRICING - US Dollars
SnapGuide for SUMO Gun Drills

1-24	25-47	48-99	100+	Bearings	SnapRings
\$7.75	\$6.50	\$6.00	\$5.50	\$13.00 (6006-2RS)	\$.25 (DSH-30)

Bearing Adaptors

International Drill Guide Inc. has designed and manufactured a variety of special bearing adaptors to retrofit our products onto countless gundrill machines, transfer lines, and other special machines. We can help you retrofit our product simply and economically on any machine with little or no lead time. Most gun drill machine builders currently stock holders for our SnapGuide® or Drill Guide designed specifically for their machines. They are another quality source for your bearing adaptor inquiries.



The color blue is a registered trademark of International Drill Guide, Inc.

Request a Free Sample

Our top quality products save time and money. Prove it in your own plant. Fill out the request form below to receive your free trial sample.



Name Title

Company Tel

Fax E-mail

Address

City, State Zip country

Product requested

SnapGuide® O.D.	<input type="text"/> Drill size	DRILL TYPE (Check One)
Drill Guide	<input type="text"/> Drill size	Single Flute <input type="checkbox"/>
Chip Deflector	<input type="text"/> Drill size	Two Flute <input type="checkbox"/>
		Other <input type="checkbox"/>

International Drill Guide, Inc. Fax Number 864.226.0832