



INTERNATIONAL
Drill Guide, INC.



Gun Drill and other
deep hole tooling.

Contents

Contents & How to Use This Guide	2
About International Drill Guide, Inc.	3
SnapGuide® Product and Benefits	4-5
17mm OD SnapGuide®	6
20mm OD SnapGuide®	7
30mm OD SnapGuide®	8-9
45mm OD SnapGuide®	10
75mm OD SnapGuide®	11
17, 20, 30, 45, 75mm OD SnapGuide® Specials	12
SnapGuide® for BTA Drills	13
About Drill Guides	14
Drill Guide Sizing Charts	15-16
Special Drill Guides	17-18
BTA Drill Guides	19
About Chip Deflectors	20
Chip Deflectors Sizing Charts and Pricing	21
32 and 40mm O.D. Chip Deflectors	22
Small Diameter Sizes SnapGuide®	23
15mm OD SnapGuide®/Extra Wide Drill Guides	24
SnapGuides and Drill Guides for Allied Drill	25
SnapGuide® Bushings for Sumo Gun Drills	26
Bearing Adaptor and Free Sample Request	27

How to use this Guide

All part specification pages are arranged with the following helpful guide points as shown below.

Page Subject — 17 MM OD SnapGuide™

Page Number — 6

Part Notes — NOTE: All SnapGuide™ bushings should be used with round holes. Custom hole bushings in these sizes may contribute to premature tool breakage. Call us for custom bushings in this range and we will meet your application.

Advice in selecting the best parts. — The BEST SnapGuide™ to use when drilling any hole... 50% or smaller.

Pricing Information — PRICING - US Dollars 17 mm OD Bushing

Size Selection Guide — Diagram showing Drill Range and Schematic Size Guide.

Part Sizes — Table listing Part No., Drill Range, and Part No. for various sizes.

Quantity - Quantity Discounts for Individual sizes only

1-24	25-49	50-99	100+	Bushings	Snap Rings
\$0.75	\$0.25	\$4.25	\$3.25	\$8.00 (600.20)	\$20 (100/17)

About International Drill Guide, Inc.

International Drill Guide, Inc. manufactures a full line of plastic support bushings and chip box seals for all deep hole drilling machines. Our products stop drill whipping, reduce vibration, increase hole accuracy and seal the chip box on every gun drill machine. We offer the best application engineering to optimize your job coupled with expertise in Chemistry and Polymers to maximize bushing life and performance. The products are molded on our state of the art CNC molding machine. Specials can be designed and built with minimal lead time in our own CNC mold making shop. Our signature **Blue Bushings®** always guarantee you top quality.

3



The color blue is a registered trademark of International Drill Guide, Inc.

Pricing and specifications subject to change with out notice.

T 864.225.2214

F 864.226.0832

www.gundrill.com

sales@gundrill.com



SnapGuide®

Quick-change support bushing held in place with snap ring.

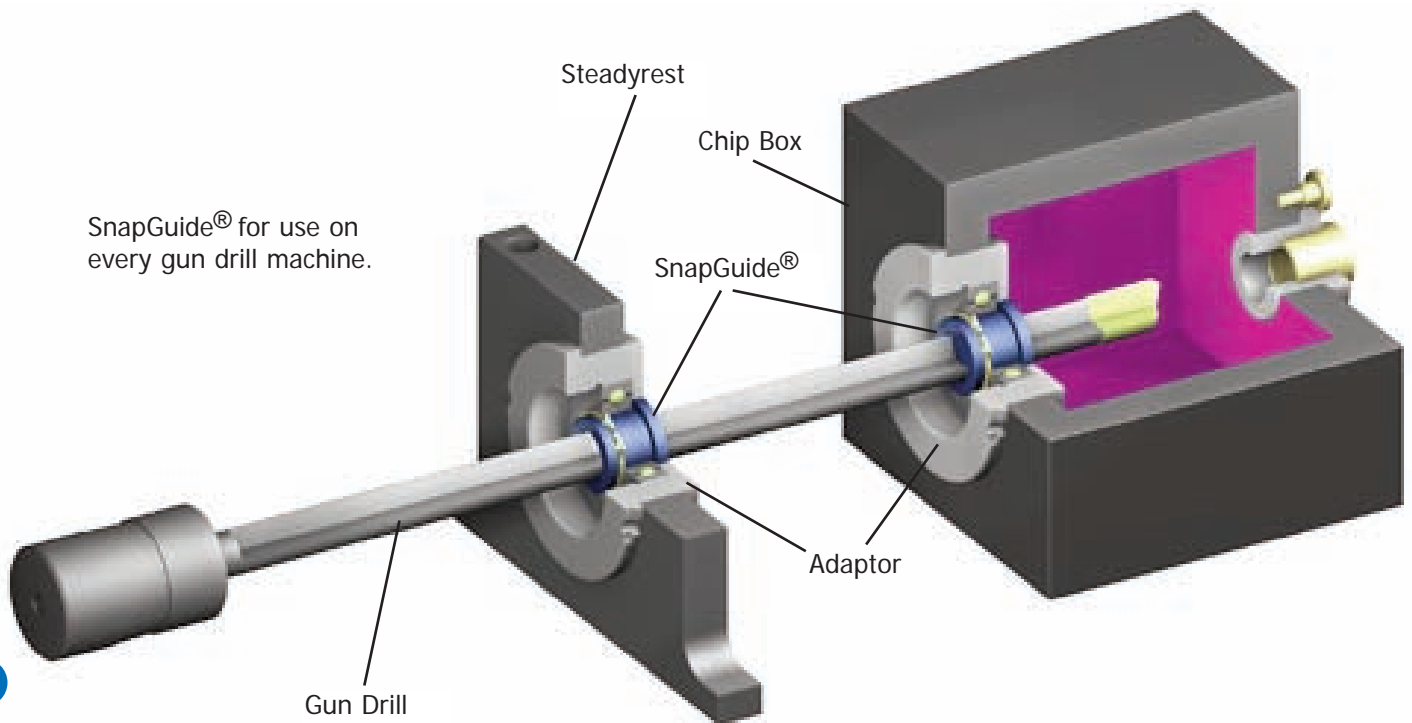

4

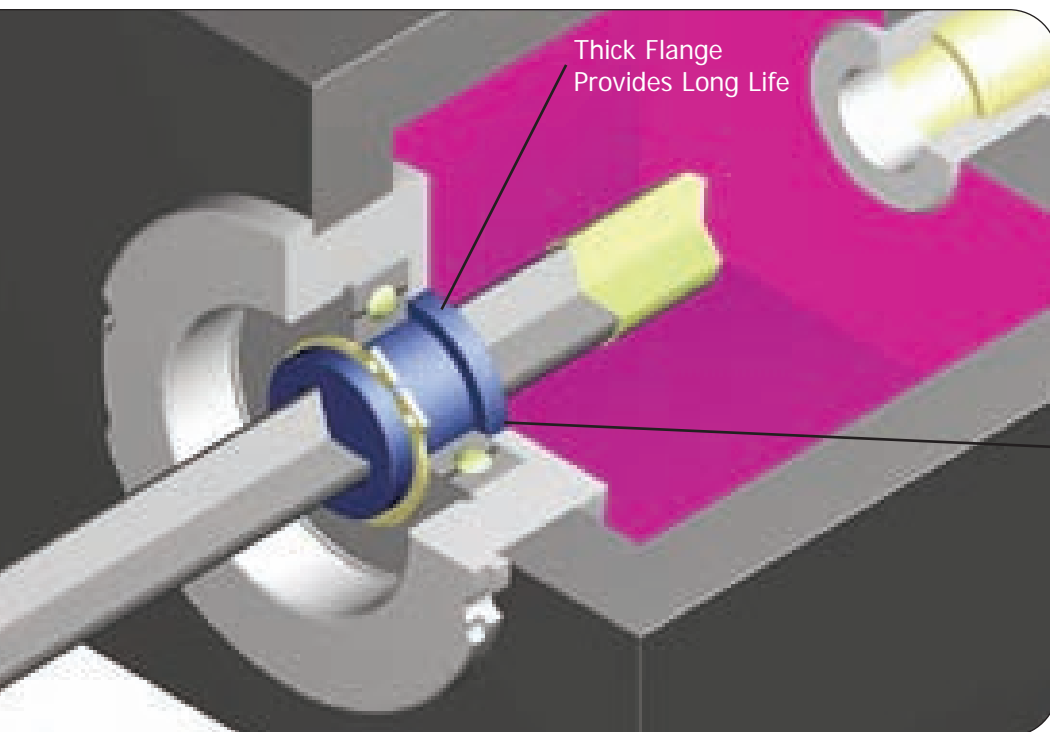

Chip Box

Flexible plastic SnapGuide® bushings stretch over carbide gun drill tip and contract over steel tube to stop drill whipping and vibration. Contoured hole in SnapGuide® forms perfect seal on gun drill.

Our signature **Blue Bushings®** always guarantee you top quality.

Steadyrest

SnapGuide® with round holes are used in the steadyrest. This speeds drill loading by eliminating the need to orient the contoured hole in the SnapGuide® with the drill. Extra clearance in SnapGuide® allows drill tip to slide through easier. Also helps prevent steadyrest from being dragged out of position.

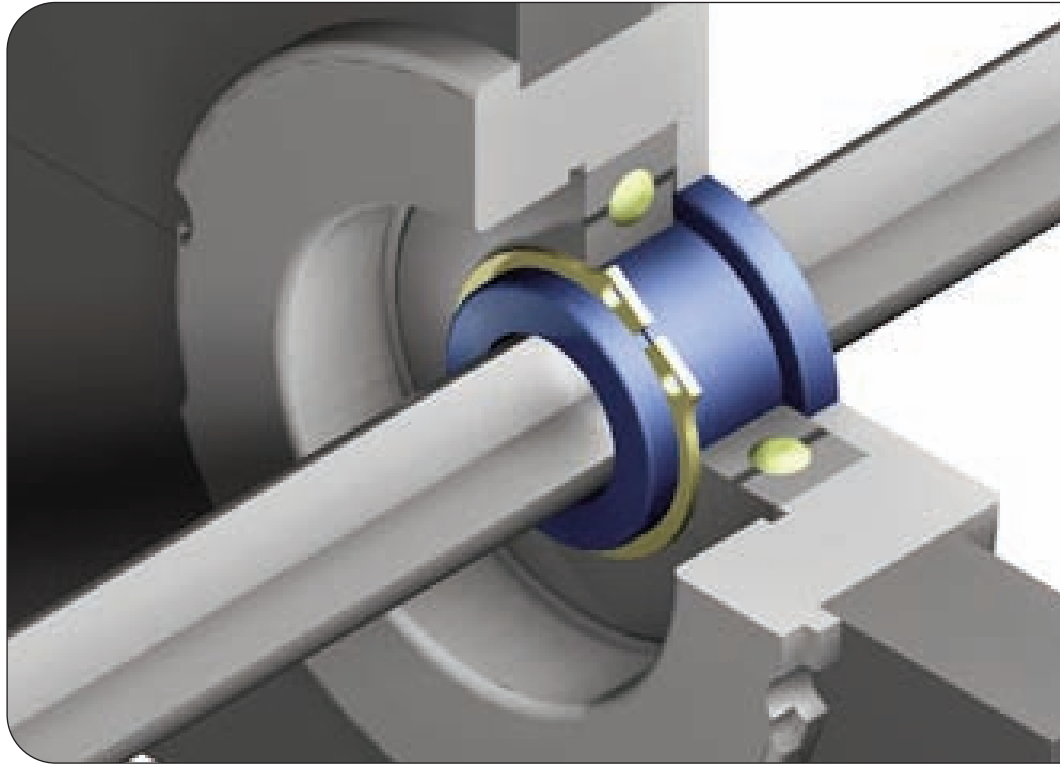

Set Up Reduction

Each bearing holder has large drill range capacity reducing or eliminating holder change-overs on machine.

SnapGuide® Drill Range

- 17mm OD - 1,70 mm - 13,00 mm
- 20mm OD - 1,70 mm - 16,00 mm
- 30mm OD - 2,90 mm - 26,99 mm
- 45mm OD - 20,80 mm - 38,69 mm
- 75mm OD - 38,70 mm - 51,00+ mm

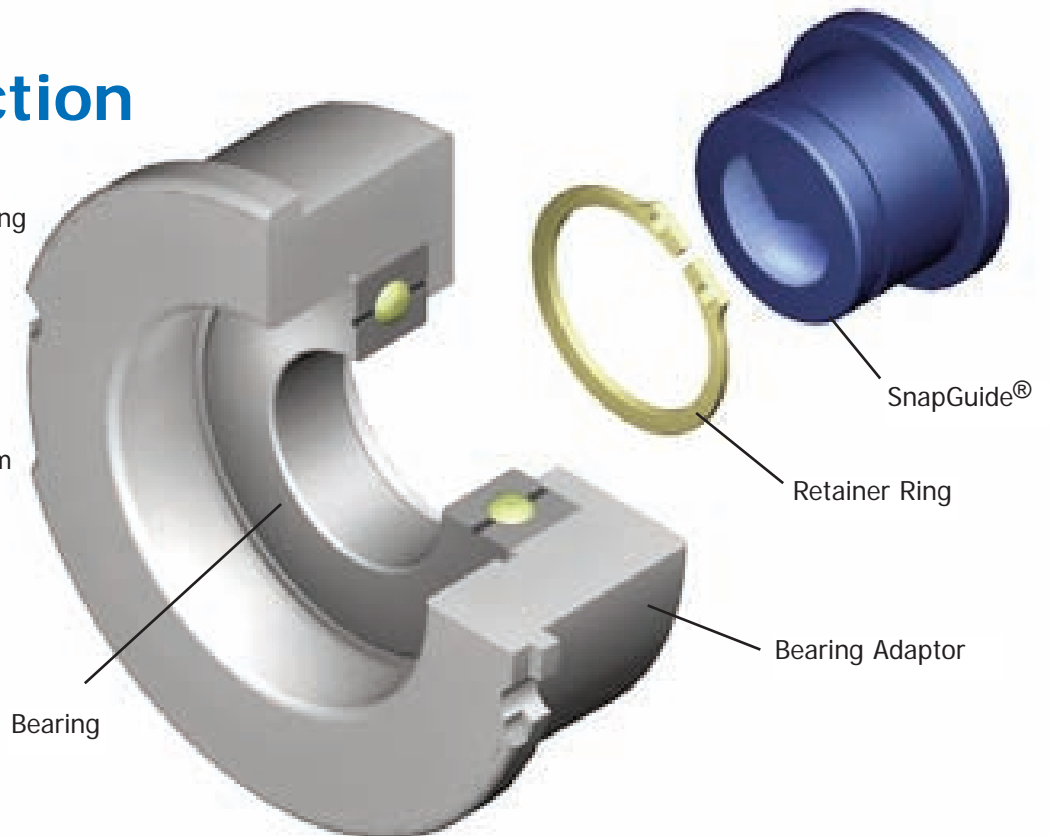

17 mm OD SnapGuide®

INTERNATIONAL Drill Guide, INC. T 864.225.2214 F 864.226.0832 gundrill.com

[Click here to request free 17mm OD SnapGuide sample](#)

6

NOTE

All SnapGuide® bushings shaded **red** have round holes. Contour hole bushings in these ranges may contribute to premature drill breakage. Call us for contour bushings in this range and we will review your application.

The **BEST** SnapGuide® to use when drilling any hole 13,499 or smaller.

PRICING - US Dollars
17mm OD Bushing

Bushing ID	Standard Part No.	Drill Range	Steadyrest Part No.	Bushing ID
0,80	0,8R-17		0,8R-17	0,80
1,20	1,2R-17		1,2R-17	1,20
1,40	1,4R-17		1,4R-17	1,40
1,67	1,67R-17		1,67R-17	1,67
1,77	1,77R-17		1,77R-17	1,77
1,87	1,87R-17	1,85 - 1,999	1,87R-17	1,87
1,97	1,97R-17	2,00 - 2,099	1,97R-17	1,97
2,07	2,07R-17	2,10 - 2,199	2,07R-17	2,07
2,17	2,17R-17	2,20 - 2,299	2,17R-17	2,17
2,27	2,27R-17	2,30 - 2,399	2,27R-17	2,27
2,37	2,37R-17	2,40 - 2,499	2,37R-17	2,37
2,47	2,47R-17	2,50 - 2,599	2,47R-17	2,47
2,57	2,57R-17	2,60 - 2,699	2,57R-17	2,57
2,67	2,67R-17	2,70 - 2,799	2,67R-17	2,67
2,8	2,8R-17	2,80 - 3,099	2,8R-17	2,8
3,0	3,0R-17	3,10 - 3,359	3,0R-17	3,0
3,2	3,2R-17	3,36 - 3,459	3,2R-17	3,2
3,4	3,4R-17	3,46 - 3,799	3,4R-17	3,4
3,5	3,5R-17		3,5R-17	3,5
3,65	3,65R-17	3,80 - 3,959	3,65R-17	3,65
3,8	3,8R-17	3,96 - 4,259	3,8R-17	3,8
3,87	3,87-17			
4,07	4,07-17	4,26 - 4,499	4,0R-17	4,27
4,27	4,27-17	4,50 - 4,749	4,27R-17	4,47
4,47	4,47-17	4,75 - 4,999	4,47R-17	4,6
4,67	4,67-17			
4,87	4,87-17	5,00 - 5,249	4,8R-17	5,0
5,07	5,07-17	5,25 - 5,499	5,0R-17	5,2
5,27	5,27-17	5,50 - 5,749	5,2R-17	5,4
5,47	5,47-17	5,75 - 5,999	5,47R-17	5,47
5,67	5,67-17		5,67R-17	5,67
5,75	5,75-17	6,00 - 6,249	5,75R-17	5,75
6,0	6,0-17	6,25 - 6,449	6,0R-17	6,0
6,25	6,25-17	6,45 - 6,749	6,25R-17	6,25
6,6	6,6-17	6,75 - 7,299	6,6R-17	6,6
6,9	6,9-17	7,30 - 7,599	6,9R-17	6,9
7,2	7,2-17	7,60 - 7,799	7,2R-17	7,2
7,5	7,5-17	7,80 - 7,999	7,45R-17	7,45
7,8	7,8-17	8,00 - 8,699	7,8R-17	7,8
8,15	8,15-17		8,15R-17	8,15
8,45	8,45-17	8,70 - 8,999	8,45R-17	8,45
8,65	8,65-17	9,00 - 9,299	8,65R-17	8,65
9,15	9,15-17	9,30 - 9,699	9,15R-17	9,15
9,45	9,45-17	9,70 - 9,999	9,45R-17	9,45
9,75	9,75-17	10,00 - 10,299	9,75R-17	9,75
10,05	10,05-17	10,30 - 10,799	10,05R-17	10,05
10,45	10,45-17	10,80 - 11,299	10,45R-17	10,45
10,85	10,85-17	11,30 - 11,799	10,85R-17	10,9
11,15	11,15-17		11,15R-17	11,15
11,55	11,55-17	11,80 - 12,399	11,55R-17	11,55
11,75	11,75-17		11,75R-17	11,75
12,1	12,1-17	12,40 - 12,899	12,1R-17	12,1

Bearing dimensions 35 mm OD x 10 mm wide x 17 mm bore

Quantity discounts for individual sizes only

1-24	25-47	48-99	100+	Bearings	Snap Rings
\$6.15	\$5.62	\$4.55	\$3.48	\$8.56 (6003-2RS)	\$.27 (DSH-17)

Bushing ID	Chip Box SnapGuide® Standard Part No.	Appropriate Drill Sizes Drill Range	Steady Rest SnapGuide® Steadyrest Part No.	Bushing ID
1,8	1,8R-20		1,8R-20	1,8
1,9	1,9R-20	1,85 - 1,999	1,9R-20	1,9
2,0	2,0R-20	2,00 - 2,099	2,0R-20	2,0
2,1	2,1R-20	2,10 - 2,199	2,1R-20	2,1
2,2	2,2R-20	2,20 - 2,299	2,2R-20	2,2
2,3	2,3R-20	2,30 - 2,399	2,3R-20	2,3
2,4	2,4R-20	2,40 - 2,499	2,4R-20	2,4
2,5	2,5R-20	2,50 - 2,599	2,5R-20	2,5
2,6	2,6R-20	2,60 - 2,699	2,6R-20	2,6
2,7	2,7R-20	2,70 - 2,799	2,7R-20	2,7
2,8	2,8R-20	2,80 - 3,099	2,8R-20	2,8
3,0	3,0R-20	3,10 - 3,359	3,0R-20	3,0
3,2	3,2R-20	3,36 - 3,459	3,2R-20	3,2
3,4	3,4R-20	3,46 - 3,559	3,4R-20	3,4
3,5	3,5R-20	3,56 - 3,959	3,5R-20	3,5
3,8	3,8R-20	3,96 - 4,259	3,8R-20	3,8
4,0	4,0R-20	4,26 - 4,499	4,0R-20	4,0
4,2	4,2R-20	4,50 - 4,749	4,2R-20	4,2
4,27	4,27-20		4,4R-20	4,4
4,47	4,47-20	4,75 - 4,999	4,47R-20	4,47
			4,6R-20	4,6
4,67	4,67-20	5,00 - 5,249	4,67R-20	4,67
			4,8R-20	4,8
4,87	4,87-20			
5,07	5,07-20	5,25 - 5,449	5,0R-20	5,2
5,27	5,27-20	5,50 - 5,749	5,2R-20	5,4
5,47	5,47-20	5,75 - 5,999	5,47R-20	5,47
5,67	5,67-20		5,67R-20	5,6
5,75	5,75-20	6,00 - 6,249	5,75R-20	5,75
6,0	6,0-20	6,25 - 6,449	6,0R-20	6,0
6,25	6,25-20	6,45 - 6,749	6,25R-20	6,25
6,6	6,6-20	6,75 - 7,299	6,6R-20	6,6
6,9	6,9-20	7,30 - 7,599	6,9R-20	6,9
7,2	7,2-20	7,60 - 7,799	7,2R-20	7,2
7,5	7,50-20	7,80 - 7,999	7,5R-20	7,5
7,8	7,8-20	8,00 - 8,699	7,80R-20	7,8
			8,0R-20	8,0
8,15	8,15-20		8,15R-20	8,15
8,45	8,45-20	8,70 - 8,999	8,45R-20	8,45
8,65	8,65-20	9,00 - 9,299	8,65R-20	8,65
9,15	9,15-20	9,30 - 9,699	9,15R-20	9,15
9,45	9,45-20	9,70 - 9,999	9,45R-20	9,45
9,65	9,65-20			
9,75	9,75-20	10,00 - 10,299	9,75R-20	9,75
10,05	10,05-20	10,30 - 10,799	10,05R-20	10,05
10,45	10,45-20	10,80 - 11,299	10,45R-20	10,45
10,85	10,85-20	11,30 - 11,799	10,85R-20	10,85
11,15	11,15-20		11,15R-20	11,15
11,55	11,55-20	11,80 - 12,399	11,55R-20	11,55
11,75	11,75-20	12,40 - 12,899	11,75R-20	11,75
12,4	12,4-20	12,90 - 13,399	12,4R-20	12,4
12,8	12,8-20	13,40 - 13,899	12,8R-20	12,8
13,3	13,3-20	13,90 - 14,399	13,3R-20	13,3
13,8	13,8-20	14,40 - 14,899	13,8R-20	13,8
14,3	14,3-20	14,90 - 15,399	14,3R-20	14,3
14,8	14,8-20	15,40 - 15,899	14,8R-20	14,8
15,25	15,25-20		15,25R-20	15,25
15,4	15,4-20	15,90 - 16,399	15,4R-20	15,4

Bearing dimensions 42 mm OD x 12 mm wide x 20 mm bore

Quantity discounts for individual sizes only

1-24	25-47	48-99	100+	Bearings	Snap Rings
\$7.22	\$5.89	\$4.82	\$3.75	\$10.70 (6004-2RS)	\$.27 (DSH-20)

20 mm OD SnapGuide®

INTERNATIONAL Drill Guide, INC. T 864.225.2214 F 864.226.0832 gundrill.com

[Click here to request free 20mm OD SnapGuide sample](#)

NOTE
All SnapGuide® bushings shaded red have round holes. Contour hole bushings in these ranges may contribute to premature drill breakage. Call us for contour bushings in this range and we will review your application.

The **BEST** SnapGuide® to use for any hole smaller than 16,399 but larger than 13,499. Also best when a bushing with total range of 1,70 - 16,399 is required.

PRICING - US Dollars
20mm OD Bushing

30 mm OD SnapGuide®

INTERNATIONAL
Drill Guide, INC. T 864.225.2214
F 864.226.0832
gundrill.com

[Click here to request free
30mm OD SnapGuide sample](#)

8

NOTE

All SnapGuide® bushings shaded **red** have round holes. Contour hole bushings in these ranges may contribute to premature drill breakage. Call us for contour bushings in this range and we will review your application.

The **BEST** SnapGuide® for large holes up to 26,99. Excellent job shop bushing with largest range of any of our bushings. Drill range is 2,40 - 26,99.

Bushing ID	Standard Part No.	Drill Range	Steadyrest Part No.	Bushing ID
		Appropriate Drill Sizes		
2,3	2,3R-30	2,30 - 2,499	2,3R-30	2,3
2,8	2,8R-30	2,90 - 3,099	2,8R-30	2,8
3,0	3,0R-30	3,10 - 3,359	3,0R-30	3,0
3,2	3,2R-30	3,36 - 3,459	3,2R-30	3,2
3,4	3,4R-30	3,46 - 3,559	3,4R-30	3,4
3,5	3,5R-30	3,56 - 3,799	3,5R-30	3,5
3,8	3,8R-30	3,80 - 4,259	3,8R-30	3,8
4,0	4,0R-30	4,26 - 4,499	4,0R-30	4,0
4,2	4,2R-30	4,50 - 4,749	4,2R-30	4,2
4,4	4,4R-30		4,4R-30	4,4
4,6	4,6R-30	4,75 - 4,999	4,6R-30	4,6
4,8	4,8R-30	5,00 - 5,249	4,8R-30	4,8
5,0	5,0R-30	5,25 - 5,499	5,0R-30	5,0
5,07	5,07-30		5,2R-30	5,2
5,27	5,27-30	5,50 - 5,749	5,4R-30	5,4
5,47	5,47-30	5,75 - 5,999	5,47R-30	5,47
5,67	5,67-30		5,6R-30	5,6
5,75	5,75-30	6,00 - 6,249	5,8R-30	5,8
6,0	6,0-30	6,25 - 6,449	6,0R-30	6,0
6,25	6,25-30	6,45 - 6,749	6,25R-30	6,25
6,6	6,6-30	6,75 - 7,299	6,6R-30	6,6
			6-8R-30	6,8
6,9	6,9-30	7,30 - 7,599	6,9R-30	6,9
7,2	7,2-30	7,60 - 7,799	7,2R-30	7,2
7,5	7,5-30	7,80 - 7,999	7,45R-30	7,45
7,8	7,8-30	8,00 - 8,299	7,80R-30	7,8
8,15	8,15-30	8,3 - 8,699	8,15R-30	8,15
8,45	8,45-30	8,70 - 8,999	8,45R-30	8,45
8,65	8,65-30	9,00 - 9,299	8,65R-30	8,65
			8,85R-30	8,8
			8,9R-30	8,9
9,15	9,15-30	9,30 - 9,699	9,15R-30	9,15
9,45	9,45-30	9,70 - 9,999	9,45R-30	9,45
9,75	9,75-30	10,00 - 10,299	9,75R-30	9,75
			9,9R-30	9,9
10,05	10,05-30	10,30 - 10,799	10,05R-30	10,05
10,45	10,45-30	10,80 - 11,299	10,45R-30	10,45
10,85	10,85-30	11,30 - 11,799	10,9R-30	10,9
11,15	11,15-30		11,15R-30	11,15
11,55	11,55-30	11,80 - 12,399	11,55R-30	11,55
11,75	11,75-30	12,40 - 12,899	11,75R-30	11,75
			11,9R-30	11,9
12,4	12,4-30	12,90 - 13,399	12,4R-30	12,4
12,8	12,8-30	13,40 - 13,899	12,8R-30	12,8
			12,9R-30	12,9
13,3	13,3-30	13,90 - 14,399	13,3R-30	13,3
13,8	13,8-30	14,40 - 14,899	13,8R-30	13,8
			13,9R-30	13,9
14,3	14,3-30	14,90 - 15,399	14,3R-30	14,3
14,8	14,8-30	15,40 - 15,899	14,8R-30	14,8
			14,9R-30	14,9
15,25	15,25-30		15,25R-30	15,25
15,6	15,6-30	15,90 - 16,399	15,6R-30	15,6

Continued on next page

30mm OD SnapGuide®

CONTINUED

INTERNATIONAL Drill Guide, INC. T 864.225.2214 F 864.226.0832 gundrill.com

[Click here to request free 30mm OD Snap Guide sample](#)

NOTE

All SnapGuide® bushings shaded red have round holes. Contour hole bushings in these ranges may contribute to premature drill breakage. Call us for contour bushings in this range and we will review your application.

The **BEST** SnapGuide® for large holes up to 26,99. Excellent job shop bushing with largest range of any of our bushings. Drill range is 2,40 - 26,99.

PRICING - US Dollars
30mm OD Bushing

Bushing ID	Standard Part No.	Drill Range	Steadyrest Part No.	Bushing ID
16,0	16,0-30	16,40 - 16,899	15,9R-30	15,9
16,4	16,4-30	16,90 - 17,399	16,0R-30	16,0
			16,4R-30	16,4
			16,9R-30	16,9
17,2	17,2-30	17,40 - 18,399	17,2R-30	17,2
18,0	18,0-30	18,40 - 19,509	17,9R-30	17,9
18,8	18,8-30	19,51 - 20,509	18,8R-30	18,8
			19,1R-30	19,1
19,75	19,75-30	20,51 - 21,509	19,75R-30	19,75
			19,9R-30	19,9
20,8	20,8-30	21,51 - 22,609	20,8R-30	20,8
			21,2R-30	21,2
21,5	21,5-30		21,5R-30	21,5
21,7	21,7-30		21,8R-30	21,8
22,0	22,0-30	22,61 - 23,609	22,0R-30	22,0
			22,35R-30	22,35
22,7	22,7-30		22,7R-30	22,7
			22,8R-30	22,8
23,0	23,0-30	23,61 - 24,609	23,0R-30	23,0
			23,35R-30	23,35
23,7	23,7-30			
.937	23,8-30		23,8R-30	23,8
24,0	24,0-30	24,61 - 25,609	24,0R-30	24,0
24,4	24,4-30		24,4R-30	24,4
24,9	24,9-30	25,61 - 26,609	24,9R-30	24,9

Bearing dimensions 55mm OD x 13mm wide x 30mm bore.

Note: 30 mm OD x 16 mm wide bushings also in stock. To order insert the letter "L" in front of any of the above part numbers. Example- 24,9-30 becomes L24,9-30.

Quantity discounts for individual sizes only

1-24	25-47	48-99	100+	Bearings	Snap Rings
\$8.29	\$6.96	\$6.42	\$5.89	\$13.91 (6006-2RS)	\$.27 (DSH-30)



The color blue is a registered trademark of International Drill Guide, Inc.

Pricing and specifications subject to change with out notice.

Can't find the special bushing you need? Let us quote it!

45 mm OD SnapGuide®

INTERNATIONAL Drill Guide, INC. T 864.225.2214
F 864.226.0832
gundrill.com

[Click here to request free 45mm OD SnapGuide sample](#)

10

NOTE

All SnapGuide® bushings shaded **red** have round holes. Contour hole bushings in these ranges may contribute to premature drill breakage. Call us for contour bushings in this range and we will review your application.

For Drills from 3,56 - 42,699 mm

PRICING - US Dollars
45mm OD Bushing

Bushing ID	Standard Part No.	Drill Range	Steadyrest Part No.	Bushing ID
3,4	3,4R-45	3,56 - 3,799	3,4R-45	3,4
4,5	4,5R-45	4,75 - 4,999	4,5R-45	4,5
4,75	4,75R-45	5,00 - 5,249	4,75R-45	4,75
5,75	5,75-45	6,00 - 6,249	5,75R-45	5,75
6,0	6,0-45	6,25 - 6,449	6,0R-45	6,0
6,7	6,7-45	7,00 - 7,299	6,7R-45	6,7
7,3	7,3-45	7,60 - 7,799	7,3R-45	7,3
7,7	7,7-45	8,00 - 8,299	7,7R-45	7,7
8,7	8,7-45	9,00 - 9,299	8,7R-45	8,7
9,0	9,0-45	9,30 - 9,699		
9,7	9,7-45	10,00 - 10,299	9,7R-45	9,7
10,0	10,0-45	10,30 - 10,799		
10,5	10,5-45	10,80 - 11,299		
11,0	11,0-45	11,30 - 11,799		
11,5	11,5-45	11,80 - 12,399		
12,0	12,0-45	12,40 - 12,899	12,0R-45	12,0
12,5	12,5-45	12,90 - 13,399		
13,0	13,0-45	13,40 - 13,899	13,0R-45	13,0
13,5	13,5-45	13,90 - 14,399	13,5R-45	12,5
14,0	14,0-45	14,40 - 14,899		
14,5	14,5-45	14,90 - 15,399		
15,0	15,0-45	15,40 - 15,899		
15,5	15,5-45	15,90 - 16,399	15,5R-45	15,5
16,0	16,0-45	16,40 - 16,899		
16,5	16,5-45	16,90 - 17,399		
17,0	17,0-45	17,40 - 17,899	17,0R-45	17,0
17,5	17,5-45	17,90 - 18,399	17,5R-45	17,5
18,0	18,0-45	18,40 - 19,509	18,0R-45	18,0
19,0	19,0-45	19,51 - 20,509	19,0R-45	19,0
19,8	19,8-45	20,51 - 21,509	19,8R-45	19,8
20,8	20,8-45	21,51 - 22,609	20,8R-45	20,8
21,8	21,8-45	22,61 - 23,609	21,8R-45	21,8
23,0	23,0-45	23,61 - 24,609	23,0R-45	23,0
			23,4R-45	23,4
24,0	24,0-45	24,61 - 25,609	24,0R-45	24,0
25,0	25,0-45	25,61 - 26,609	25,0R-45	25,0
26,0	26,0-45	26,61 - 27,609	26,0R-45	26,0
			26,1R-45	26,1
27,0	27,0-45	27,61 - 28,609	27,0R-45	27,0
28,0	28,0-45	28,61 - 29,609	28,0R-45	28,0
29,0	29,0-45	29,61 - 30,609	29,0R-45	29,0
30,0	30,0-45	30,61 - 32,609	30,0R-45	30,0
31,0	31,0-45		31,0R-45	31,0
32,0	32,0-45	32,61 - 34,699	32,0R-45	32,0
			33,0R-45	33,0
34,0	34,0-45	34,70 - 36,699	34,0R-45	34,0
			35,4R-45	35,4
36,0	36,0-45	36,70 - 38,699	36,0R-45	36,0
37,0	37,0-45		37,0R-45	37,0
38,0	38,0-45	38,70 - 42,699	38,0R-45	38,0

Bearing dimensions: 75 mm OD x 16 mm wide x 45 mm bore

Quantity discounts for individual sizes only

1-24	25-47	48-99	100+	Bearings	Snap Rings
\$10.70	\$10.17	\$9.10	\$8.56	\$32.10 (6009-2RS)	\$.96 (DSH-45)

75 mm OD SnapGuide®

INTERNATIONAL Drill Guide, INC. T 864.225.2214 F 864.226.0832 gundrill.com

[Click here to request free 75mm OD SnapGuide sample](#)

Bushing for drills from 39,11-51,00 +

Bushing ID	Standard Part No.	Drill Range	Steadyrest Part No.	Bushing ID
38,0	38,0-75	38,70 - 42,699	38,0R-75	38,0
39,0	39,0-75		39,0R-75	39,0
40,0	40,0-75		40,0R-75	40,0
41,0	41,0-75		41,0R-75	41,0
42,0	42,0-75	42,70 - 45,699	42,0R-75	42,0
43,0	43,0-75		43,0R-75	43,0
44,0	44,0-75		44,0R-75	44,0
45,0	45,0-75	45,70 - 48,999	45,0R-75	45,0
46,0	46,0-75		46,0R-75	46,0
47,0	47,0-75		47,0R-75	47,0
48,0	48,0-75	49,00 +	48,0R-75	48,0
49,0	49,0-75		49,0R-75	49,0
50,0	50,0-75		50,0R-75	50,0
51,1	51,1-75		51,1R-75	51,1
			56,0R-75	56,0
			62,0R-75	62,0

Bearing OD 115 mm x 20 mm wide x 75 mm bore

Quantity discounts for individual sizes only

1-24	25-47	48-99	100+	Bearings	Snap Rings
\$11.77	\$11.24	\$10.17	\$9.63	\$95.23 (6015-2RS)	\$1.66 DSH-75



PRICING US Dollars
75mm OD Bushing

2 FLUTE SnapGuide®



Bushing
ID



Bushing
OD

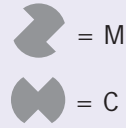

Shape & Part #

Appropriate
Drill
Sizes

Drill
Diameter

Bearing
Number

Bearing
OD

3,4036	17mm	C	3,4-2-17	3,60mm	6003-2RS	35mm
4,6736	"	C	4,7-2-17	5,1562	"	"
5,207	"	C	5,2-2-17	5,3848	"	"
5,3848	"	C	5,4-2-17	5,5626	"	"
5,969	"	C	6,0-2-17	6,35	"	"
6,86	"		6,85-2-17	"	"	"
10,3378	"	M	10,35-2-17	10,7442	"	"
12,0904	"	C	12,1-2-17	12,70	"	"
6,731	"	C	6,7-2-20	7,00mm	6004-2RS	42mm
9,35	"		9,35-2-20	"	"	"
12,09	"		12,1-2-20	"	"	"
12,4206	"	C	12,4-2-20	12,9286	"	"
8,4328	30mm	M	8,4-2-30	8,5852	6006-2RS	55mm
8,71	"		8,7-2-30	"	"	"
8,8138	"	M	8,81-2-30	9,6012	"	"
8,89	"	C	8,9-2-30	9,6012	"	"
9,60	"		9,6-2-30	"	"	"
9,906	"	C	9,9-2-30	10,0076	"	"
10,6172	"	M	10,3-2-30	11,0998	"	"
10,7188	"	M	10,7-2-30	10,9982	"	"
12,09	"		12,1-2-30	"	"	"
16,5862	"	M	16,6-2-30	17,4752	"	"
18,796	"	M	18,88-2-30	19,2786	"	"
18,9992	"	M	19,0-2-30	19,4818	"	"
19,41	"		19,4-2-30	"	"	"
20,9804	"	C	21,0-2-30	21,6916	"	"
24,4094	45mm	M	24,4-2-45	25,40	6009-2RS	75mm



INTERNATIONAL
Drill Guide, INC.

T 864.225.2214
F 864.226.0832

gundrill.com

12

Click here to request free
2 Flute SnapGuide sample

Can't find the special bushing
you need? Let us quote it!



Quantity discounts for individual sizes only

Part Numbers	1-24	25-47	48-99	100+	Bearing #	Price Each
4,7-2-17 thru 12,1-2-17	\$6.15	\$5.62	\$4.55	\$3.48	6003-2RS	\$8.56
6,7-20 thru 12,4-2-20	\$7.22	\$5.89	\$4.82	\$3.75	6004-2RS	\$10.70
8,81-2-30 thru 19,0-2-30	\$8.29	\$6.96	\$6.42	\$5.89	6006-2RS	\$13.91
24,4-2-45	\$10.70	\$10.17	\$9.10	\$8.56	6009-2RS	\$32.10

PRICING - US Dollars
2 Flute SnapGuide®



SnapGuide®



Appropriate
Drill
Sizes

Bushing ID	Standard Part No.	Drill Range	Fits BTA Tube Dia.	Required Bearing	Bearing OD
6,9	6,9R-30	8,00 - 8,99	7,0	6006-2RS	55mm
8,15	8,15R-30	9,00 - 9,99	8,3	"	"
8,9	8,9R-30	10,00 - 10,99	9,0	"	"
9,9	9,9R-30	11,00 - 11,99	10,0	"	"
10,9	10,9R-30	12,00 - 13,59	11,0	"	"
11,9	11,9R-30	13,60 - 14,59	12,0	"	"
12,9	12,9R-30	14,60 - 15,59	13,0	"	"
13,9	13,9R-30	15,60 - 16,69	14,0	"	"
14,9	14,9R-30	16,70 - 17,69	15,0	"	"
15,9	15,9R-30	17,70 - 18,89	16,0	"	"
16,9	16,9R-30	18,90 - 19,99	17,0	"	"
17,9	17,9R-30	20,00 - 21,79	18,0	"	"
19,9	19,9R-30	21,80 - 24,08	20,0	"	"
21,9	21,9R-30	24,10 - 26,39	22,0	"	"
24,0	24,0R-30	26,40 - 28,69	24,0	"	"
26,0	26,0R-45	28,70 - 30,99	26,0	6009-2RS	75mm
28,0	28,0R-45	31,00 - 33,29	28,0	"	"
30,0	30,0R-45	33,30 - 36,19	30,0	"	"
33,0	33,0R-45	36,20 - 39,59	33,0	"	"
36,0	36,0R-45	39,60 - 42,99	36,0	"	"
39,0	39,0R-75	43,00 - 46,99	39,0	6015-2RS	115mm
43,0	43,0R-75	47,00 - 51,69	43,0	"	"
47,0	47,0R-75	51,70 - 56,19	47,0	"	"
51,0	51,0R-75	56,20 - 64,99	51,0	"	"
56,0	56,0R-75	65,00 - 66,99	56,0	"	"
62,0	62,0R-75	67,00 - 72,99	62,0	"	"

BTA SnapGuide®



INTERNATIONAL
Drill Guide, INC.

T 864.225.2214
F 864.226.0832

gundrill.com

[Click here to request free BTA SnapGuide sample](#)

Quantity discounts for individual sizes only

Part Numbers	1-24	25-47	48-99	100+	Bearing #	Price Each	Snap Ring
6,9R-30 thru 24,0R-30	\$8.29	\$6.96	\$6.42	\$5.89	6006-2RS	\$13.91	\$.27 DSH-30
26,0R-45 thru 36,0R-45	\$10.70	\$10.17	\$9.10	\$8.56	6009-2RS	\$32.10	\$.96 DSH-45
39,0R-75 thru 62,0R-75	\$11.77	\$11.24	\$10.17	\$9.63	6015-2RS	\$95.23	\$1.66 DSH-75

PRICING
US Dollars
BTA Bushings

The color blue is a registered trademark of International Drill Guide, Inc.

BTA bushings are round hole bushings designed to be used on the steadyrest of BTA drilling machines. They support the drill tube with a slight compression fit and help limit vibration.



About Drill Guides

Flexible plastic Drill Guide bushings stop drill whipping and seal the chip box by stretching over the carbide drill tip and contracting onto the steel drill body. They are typically mounted in a bearing and rotate with the drill. This is our first and oldest product and is still used by many customers to maximize penetration rates, accuracy, and stop vibration. These bushings perform the same function as our SnapGuide®. Our signature **Blue Bushings®** guarantee you top quality.

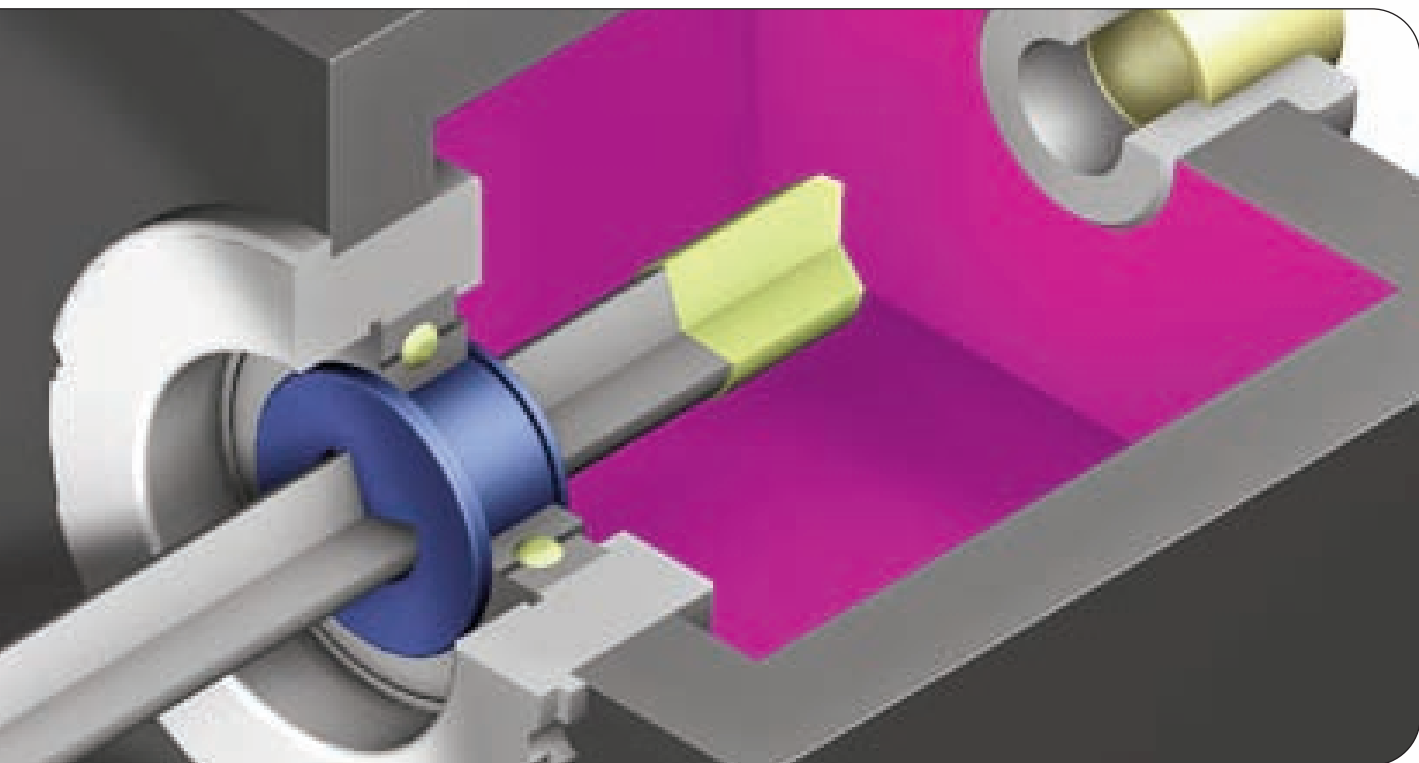
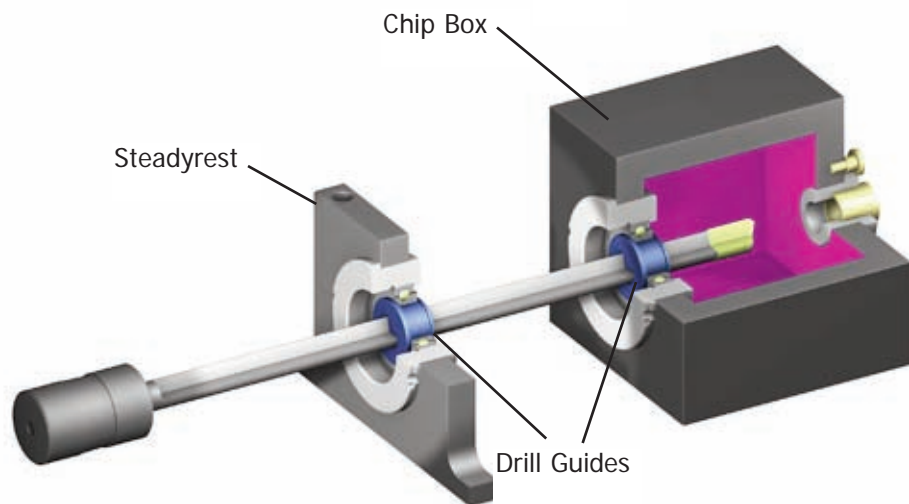



Appropriate
Drill
Sizes

Bushing ID	Drill Guide Part No.	Drill Range	Bearing ID	Bearing OD
1,78	A100	1,85 - 1,999	8	24
2,03	A110	2,00 - 2,299		
2,29	A120	2,30 - 2,599		
2,67	A130	2,60 - 3,099		
3,05	A140	3,10 - 3,459		
3,30	A150	3,46 - 3,799		
3,56	A160	3,80 - 3,959		
3,96	A170	3,96 - 4,499		
4,34	A180	4,50 - 4,999		
4,75	A190	5,00 - 5,499		
	A192			
5,00	B090	5,25 - 5,490		
5,16	B100	5,50 - 5,749	15	35
5,56	B110	5,75 - 6,249		
6,02	B120	6,25 - 6,749		
6,35	B130	6,75 - 6,999		
6,68	B140	7,00 - 7,299		
7,14	B150	7,03 - 7,799		
7,57	B160	7,80 - 8,299		
7,98	B170	8,30 - 8,699		
8,33	B174	8,70 - 8,999		
8,71	B180	9,00 - 9,299		
9,07	B190	9,30 - 9,699		
9,53	B200	9,70 - 10,299		
9,91	B210	10,30 - 10,799		
6,35	C020	6,75 - 6,999		
10,31	C100	10,80 - 11,299	20	47
10,90	C110	11,30 - 11,799		
11,10	C120			
11,51	C130	11,80 - 12,399		
11,89	C140	12,40 - 12,899		
12,29	C150	12,90 - 13,399		
12,70	C160			
12,93	C170	13,40 - 13,899		
13,49	C180	13,90 - 14,399		
13,87	C190	14,40 - 14,899		
14,27	C200	14,90 - 15,399		
11,84	D030	12,40 - 12,899	25	52
12,24	D050	12,90 - 13,399		
12,95	D070	13,40 - 13,899		
14,68	D100			
15,06	D110	15,40 - 15,899		
15,47	D120	15,90 - 16,399		
15,88	D130	16,40 - 16,899		
16,26	D140	16,90 - 17,399		
16,66	D150			
17,04	D160	17,40 - 17,899		
17,45	D170	17,90 - 18,399		
17,86	D180	18,4 - 19,509		
18,24	D190			
13,87	E050	14,40 - 14,899		
14,27	E070	14,90 - 15,399		
17,86	E090	18,40 - 19,509	35	72
18,24	E100			
18,64	E110			
19,05	E120	19,51 - 20,509		
19,43	E130			
19,84	E140	20,51 - 21,509		
20,22	E150			
20,62	E160			

Drill Guide Parts



INTERNATIONAL
Drill Guide, INC. gundrill.com

T 864.225.2214

F 864.226.0832

[Click here to request free Drill Guide sample](#)

15

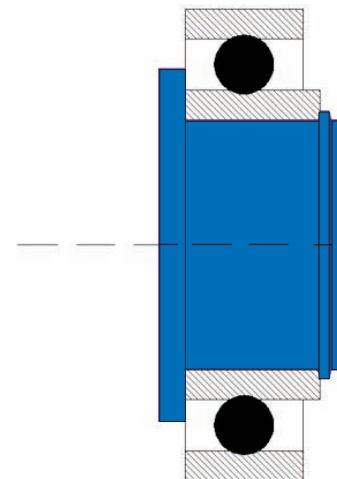

NOTE

Drill Guides are also available in a softer material by placing an "S" at the end of the part # example A100S

Continued on next page

Drill Guide Parts

CONTINUED



INTERNATIONAL
Drill Guide, INC.

T 864.225.2214
F 864.226.0832
gundrill.com

[Click here to request free
Drill Guide sample](#)

16

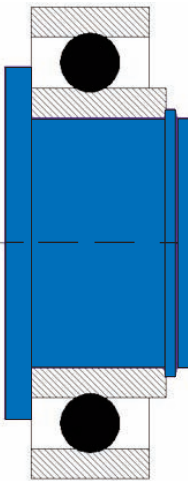

Bushing
ID

Drill Guide
Part No.

Appropriate
Drill
Sizes

Drill Range

Bearing
ID

Bearing
OD

21,03	E170	21,51 - 22,609		
21,41	E180			
21,82	E190	22,61 - 23,609		
22,23	E200			
22,61	E210			
23,01	E220	23,61 - 24,609		
23,39	E230		35	72
23,80	E240	24,61 - 25,609		
24,21	E250			
24,59	E260	25,61 - 26,609		
25,60	E280	26,61 - 27,609		
27,25	E290	27,61 - 28,609		
28,91	E300	28,61 - 29,609		
30,05	E310	30,61 - 32,609		
24,51	F100	24,61 - 25,609	45	85
25,10	F104	25,61 - 26,609		
25,53	F110			
26,11	F114	26,61 - 27,609		
27,05	F120	27,61 - 28,609		
28,83	F130	28,61 - 29,609		
29,08	F134	29,61 - 30,609		
29,97	F140	30,61 - 32,609		
31,37	F150			
32,39	F160	32,61 - 34,699		
33,15	F170			
33,91	F180			
34,19	F356	34,70 - 36,699		
35,00	F363			
34,67	G090		55	100
35,56	G100			
36,58	G110	36,70 - 38,699		
37,47	G120	38,70 - 42,699		
39,24	G130			
42,29	G140	42,70 - 45,699		
43,69	H100		65	120
45,85	H110	45,70 - 48,999		
48,90	H120	49,00+		
51,69	H130			
55,37	H140			

PRICING - US Dollars Drill Guide Parts

Quantity discounts for individual sizes only

Part #	1-9	10-24	25-47	48-99	100+	Bearing #	Price Each
A100-A190	\$8.83	\$7.22	\$5.62	\$4.55	\$3.21	87008	\$14.98
B100-B210	\$8.83	\$7.22	\$5.62	\$4.55	\$3.48	87502	\$14.98
C100-C200	\$9.10	\$7.49	\$5.89	\$4.82	\$3.75	87504	\$21.40
D030-D190	\$9.36	\$8.29	\$6.96	\$6.42	\$5.89	87505	\$23.54
E090-E310	\$9.63	\$8.56	\$8.03	\$6.96	\$6.42	87507	\$36.38
F100-F363	\$11.24	\$10.43	\$9.36	\$8.83	\$8.29	87509	\$49.22
G090-G140	\$12.31	\$11.50	\$10.43	\$9.90	\$9.36	6211-2RS	\$58.85
H100-H140	\$13.38	\$12.57	\$11.50	\$11.24	\$10.43	6213-2RS	\$75.97

NOTE

Drill Guides are also available in a softer material by placing an "S" at the end of the part # example A100S

"G" and "H" series parts also available to fit old style 211KLD and 213KLD. Call for details.

Drill Guide Parts

Two Flute & Special Bushings



INTERNATIONAL
Drill Guide, INC.

T 864.225.2214
F 864.226.0832
gundrill.com

Can't find the special bushing you need? Let us quote it!

[Click here to request free Drill Guide sample](#)

Bushing ID & Shape	Drill Guide Part No.	Drill Diameter	Bearing ID	Bearing OD
1,45 R	R057	1,52 - 1,650	8	24
1,83 R	R072	1,85 - 1,999		
1,93 R	R076	2,00 - 2,099		
2,03 R	R080	2,10 - 2,199		
2,11 R	R083	2,20 - 2,299		
2,21 R	R087	2,30 - 2,399		
2,31 R	R091	2,40 - 2,499		
2,41 R	R095	2,50 - 2,599		
2,54 R	R100	2,60 - 2,699		
2,67 R	R105	2,70 - 2,899		
2,79 R	R110	2,90 - 3,099		
2,92 R	R115			
3,02 R	R119	3,10 - 3,359		
3,40 R	R134	3,46 - 3,799		
4,29 R	R169	4,50 - 4,749		
4,88 R	R192	5,00 - 5,249		
4,24 C	A185	4,76		
4,50 R	R177	4,75 - 4,999		
4,75 R	R187	5,00 - 5,249		
5,54 R	R218	5,75 - 5,999	15	35
5,84 R	R230	6,00 - 6,249		
5,97 R	R235	6,25 - 6,449		
6,07 R	R239	6,45 - 6,749		
5,54 M	B115	6,35		
6,60 C	B123	7,14		
6,38 M	B135	7,14		
6,60 M	B137	7,14		
7,37 C	B145	7,92		
7,11 M	B155	7,92		
7,24 C	B157	7,92		
7,92 M	B175	8,74		
8,71 M	B195	9,53		
8,84 C	B197	9,53		
9,50 M	B215	10,31		
9,53 C	B217	10,01		
9,60 C	C095	10,20	20	47
9,78 M	C103	10,59		
10,29 M	C105	11,10		
10,46 R	R412			
11,10 M	C125	11,89		
11,89 M	C145	12,70		

Continued on page 18

Note: More round hole bushings on page 19 under BTA Drill Guides

Drill Guide Parts

Two Flute & Special Bushings

CONTINUED

INTERNATIONAL Drill Guide, INC. T 864.225.2214 F 864.226.0832 gundrill.com

Click here to request free Drill Guide sample

18

PRICING - US Dollars
Drill Guide Parts
Two Flute & Special Bushings

Bushing ID & Shape	Drill Guide Part No.	Drill Diameter	Bearing ID	Bearing OD
12,70 M	C165	13,49		
13,46 M	C185	14,27		
13,97 M	C195	14,81		
14,27 M	C205	15,06		
14,86 M	D115	15,88	25	52
15,62 M	D135	16,66		
16,38 M	D155	17,45		
16,89 M	D165	17,70		
17,27 M	D175	18,24		
18,03 M	D185	19,05		
19,61 M	E103	20,62	35	72
19,69 C	E104	20,62		
19,48 M	E105	19,99		
23,50 M	E235	24,00		
25,53 M	E295	27,31		
29,21 M	E305	30,00		
41,88 M	H095			
45,72 M	H097			
47,24 M	H115			
49,48 M	H125			
51,05 M	H135			

Note: More round hole bushings on page 19 under BTA Drill Guides

Quantity discounts for individual sizes only

Part #	1-9	10-24	25-47	48-99	100+	Bearing #	Price Each
A185	\$8.83	\$7.22	\$5.62	\$4.55	\$3.21	87008	\$14.98
B115-B215	\$8.83	\$7.22	\$5.62	\$4.55	\$3.48	87502	\$14.98
C103-C205	\$9.10	\$7.49	\$5.89	\$4.82	\$3.75	87504	\$21.40
D115-D185	\$9.36	\$8.29	\$6.96	\$6.42	\$5.89	87505	\$23.54
E103-E305	\$9.63	\$8.56	\$8.03	\$6.96	\$6.42	87507	\$36.38
R057-R169	\$8.83	\$7.22	\$5.62	\$4.55	\$3.21	87008	\$14.98
R230-R239	\$8.83	\$7.22	\$5.62	\$4.55	\$3.48	87502	\$14.98



Can't find the special bushing you need? Let us quote it!

BTA

Drill Guides

Bushing ID	Standard Part No.	Appropriate Drill Sizes Drill Range	Fits BTA Tube Dia.	Required Bearing	Bearing OD
7,0	R276	8,00 - 8,99	7,0	87502	35
8,2	R323	9,00 - 9,99	8,3		
8,9	R350	10,00 - 10,99	9,0		
9,9	R390	11,00 - 11,99	10,0		
10,9	R429	12,00 - 13,59	11,0	87504	47
11,9	R468	13,60 - 14,59	12,0		
12,9	R508	14,60 - 15,59	13,0		
13,9	R547	15,60 - 16,69	14,0		
14,9	R587	16,70 - 17,69	15,0	87505	52
15,9	R626	17,70 - 18,89	16,0		
16,9	R666	18,90 - 19,99	17,0		
17,9	R705	20,00 - 21,79	18,0		
19,9	R783	21,80 - 24,08	20,0	87507	72
21,9	R862	24,10 - 26,39	22,0		
23,9	R941	26,40 - 28,69	24,0		
25,9	R1020	28,70 - 30,99	26,0	87509	85
27,9	R1098	31,00 - 33,29	28,0		
29,9	R1177	33,30 - 36,19	30,0		
32,9	R1295	36,20 - 39,59	33,0		
35,9	R1413	39,60 - 42,99	36,0	6211-2RS	100
38,9	R1531	43,00 - 46,99	39,0		
42,9	R1689	47,00 - 51,69	43,0		
46,9	R1846	51,70 - 56,19	47,0	6213-2RS	120
50,9	R2004	56,20 - 64,99	51,0		
55,9	R2201	65,00 - 66,99	56,0		
61,9	R2437	67,00 - 72,99	62,0		

INTERNATIONAL Drill Guide, INC. T 864.225.2214 F 864.226.0832 gundrill.com

[Click here to request free Drill Guide sample](#)

Quantity - Quantity discounts for individual sizes only

Part #	1-9	10-24	25-47	48-99	100+	Bearing #	Price Each
R276-R390	\$8.83	\$7.22	\$5.62	\$4.55	\$3.48	87502	\$14.98
R429-R547	\$9.10	\$7.49	\$5.89	\$4.82	\$3.75	87504	\$21.40
R587-R705	\$9.36	\$8.29	\$6.96	\$6.42	\$5.89	87505	\$23.54
R783-R941	\$9.63	\$8.56	\$8.03	\$6.96	\$6.42	87507	\$36.38
R1020-R1413	\$11.24	\$10.43	\$9.36	\$8.83	\$8.29	87509	\$49.22
R1531-R1689	\$12.31	\$11.50	\$10.43	\$9.90	\$9.36	6211-2RS	\$58.85
R1846-R2437	\$13.38	\$12.57	\$11.50	\$11.24	\$10.43	6213-2RS	\$75.97

PRICING - US Dollars BTA Bushings

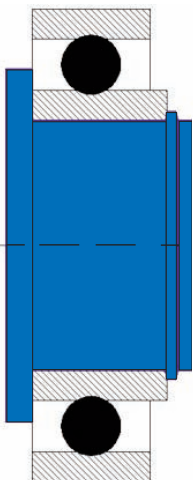

The color blue is a registered trademark of International Drill Guide, Inc.

BTA bushings are round hole bushings designed to be used on the steadyrest of BTA drilling machines. They support the drill tube with a slight compression fit and help limit vibration.

Chip Deflectors

Chip Deflectors stop metal chips and cutting oil from exiting the back of the chip box. They provide sealing only and no drill support. They are used on gun drill machines on short rigid drills when whipping is not a problem. They are also used in front of a Drill Guide or a SnapGuide® to extend bushing and bearing life. Chip Deflectors feature a hardened steel face bonded to a flexible polymer backing to provide perfect sealing on the drill and long life.

20

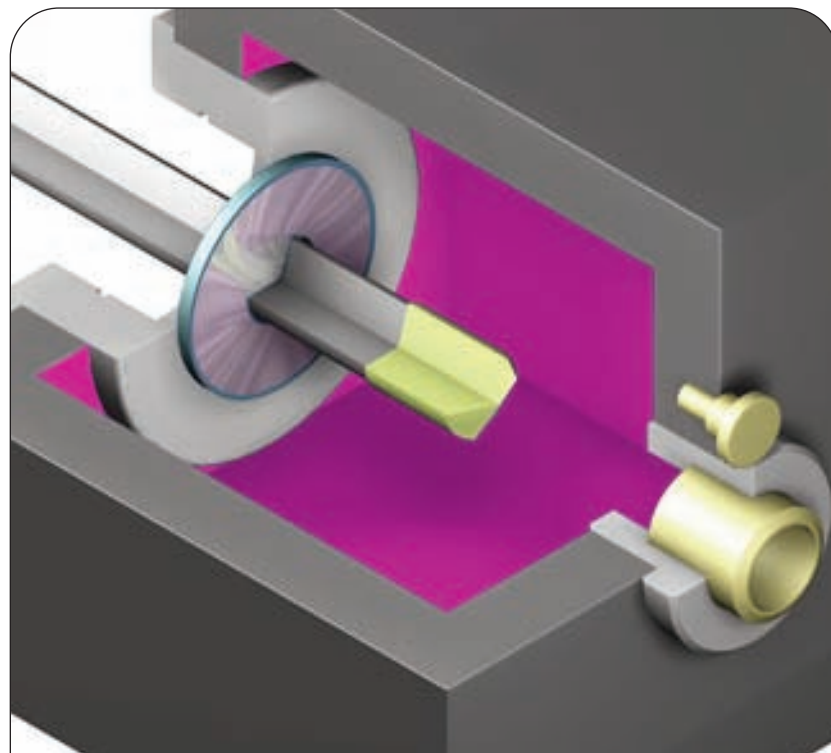
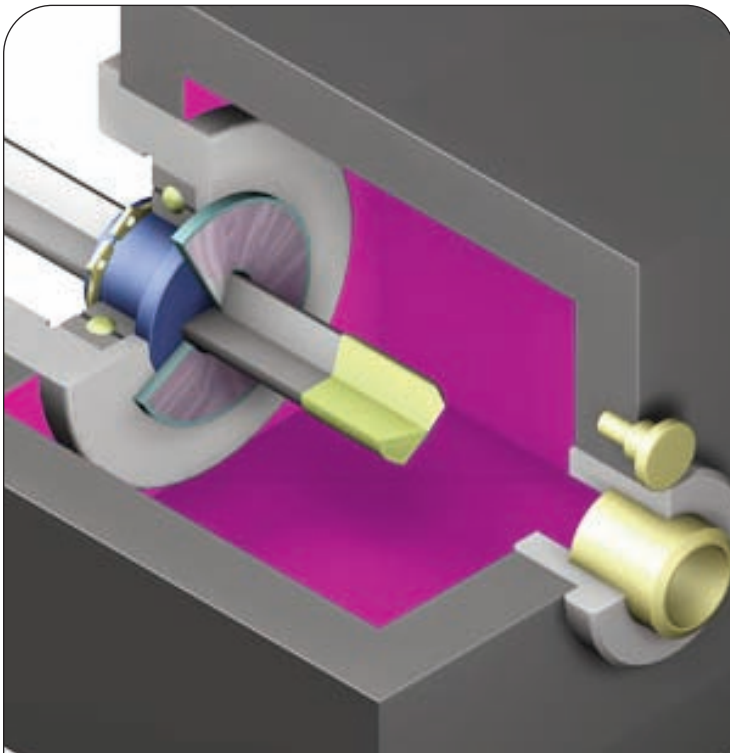

Appropriate
Drill
Sizes

Appropriate
Drill
Sizes

Appropriate
Drill
Sizes

Chip Deflectors

Part # Drill Range

Part # Drill Range

Part # Drill Range

070	1,85 - 1,999
075	2,00 - 2,099
080	2,10 - 2,199
085	2,20 - 2,399
090	2,40 - 2,499
095	2,50 - 2,599
100	2,60 - 2,699
105	2,70 - 2,899
110	2,90 - 3,099
115	
120	3,10 - 3,359
125	3,36 - 3,459
130	3,46 - 3,559
135	3,56 - 3,799
140	3,80 - 3,959
145	
150	3,96 - 4,259
155	4,26 - 4,499
160	
165	4,50 - 4,749
170	
175	4,75 - 4,999
180	
185	5,00 - 5,249
190	
195	5,25 - 5,499
200	
205	5,50 - 5,749
210	
215	5,75 - 5,999
220	
225	6,00 - 6,249
230	
235	6,25 - 6,449
240	
245	6,45 - 6,749
250	
255	6,75 - 6,999
265	7,00 - 7,299
275	7,30 - 7,599
280	
285	7,60 - 7,799
295	7,80 - 7,999
305	8,00 - 8,299

315	8,30 - 8,699
325	
335	8,70 - 8,999
345	9,00 - 9,299
355	9,30 - 9,699
365	
370	9,70 - 9,999
375	
385	10,00 - 10,299
400	10,30 - 10,799
410	10,80 - 11,299
415	
420	
430	11,30 - 11,799
445	
460	11,80 - 12,399
475	12,40 - 12,899
490	12,90 - 13,399
505	13,40 - 13,899
520	
535	13,90 - 14,399
545	14,40 - 14,899
560	
570	14,90 - 15,399
580	
600	15,40 - 16,399
620	
630	16,40 - 16,899
640	16,90 - 17,399
660	17,40 - 17,899
680	17,90 - 18,399
700	18,40 - 19,509
720	
40-19,3S	19,80 - 20,799
40-20,3S	20,80 - 21,799
40-21,3S	21,80 - 22,799
800	
820	21,51 - 22,609
840	
860	22,61 - 23,609
40-22,3S	22,80 - 23,799
920	
940	24,61 - 25,609
40-24,3S	24,80 - 25,999

993	25,61 - 26,609
1033	26,61 - 27,609
1080	27,61 - 28,609
1150	28,61 - 30,609
1195	30,61 - 32,609
1250	32,61 - 34,699
1320	34,70 - 36,699
1455	36,70 - 38,699
1575	38,70 - 42,699
1680	42,70 - 45,699
1820	45,70 - 48,999
1940	49,00 - +

INTERNATIONAL Drill Guide, INC. T 864.225.2214 F 864.226.0832 gundrill.com

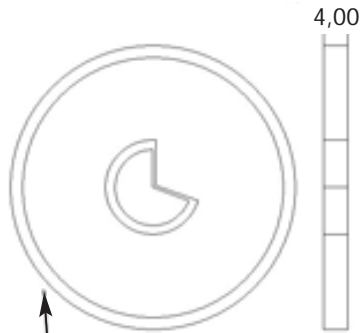

Click here to request free Chip Deflector sample

24,7 for drills 1,5 - 5,49
 37,0 for drills 5,5 - 10,5
 40,0 for part # 40-19,3S - 40,24,3S
 52,3 for drills 10,6 - 19,7
 72,6 for drills 19,8 - 50,0



Quantity discounts for individual sizes only

Part #	Pricing	Discounts
070 - 110	\$4.82 each	10% off 100 or more any one size
115 - 235	\$4.28 each	10% off 100 or more any one size
240 - 355	\$5.35 each	10% off 100 or more any one size
365 - 600	\$6.42 each	10% off 100 or more any one size
620 - 720	\$7.49 each	10% off 100 or more any one size
40-19,3S - 40-24,3S	\$8.56 each	10% off 100 or more any one size
800 - 1195	\$8.56 each	10% off 100 or more any one size
1250 - 1680	\$10.70 each	10% off 100 or more any one size
1820 - 1940	\$12.84 each	10% off 100 or more any one size

PRICING - US Dollars
Chip Deflectors

32mm & 40mm OD Chip Deflectors

**INTERNATIONAL
Drill Guide, INC.** T 864.225.2214
F 864.226.0832
gundrill.com

Appropriate
Drill
Sizes

Part #	Drill Range
32-4,85	5.00 - 5.249
32-5,05	5.25 - 5.449
32-5,25	5.45 - 5.649
32-5,45	5.65 - 5.849
32-5,65	5.85 - 5.999
32-5,85	6.00 - 6.299
32-6,05	6.30 - 6.499
32-6,25	6.50 - 6.799
32-6,55	6.80 - 7.099
32-6,85	7.10 - 7.399
32-7,15	7.40 - 7.699
32-7,45	7.70 - 7.999
32-7,75	8.00 - 8.299
32-8,05	8.30 - 8.699

Appropriate
Drill
Sizes

Part #	Drill Range
32-8,4	8.70 - 8.999
32-8,7	9.00 - 9.299
32-9,0	9.30 - 9.699
32-9,4	9.70 - 9.999
32-9,7	10.00 - 10.299
32-10,0	10.30 - 10.599
32-10,3	10.60 - 10.999
32-10,7	11.00 - 11.399
32-11,1	11.40 - 11.699
32-11,4	11.70 - 12.099
32-11,8	12.10 - 12.449
32-12,15	12.45 - 12.949
32-12,65	12.95 - 13.449
32-13,15	13.45 - 13.949

Appropriate
Drill
Sizes

Part #	Drill Range
32-13,65	13.95 - 14.449
32-14,15	14.45 - 14.949
32-14,65	14.95 - 15.559
40-15,2	15.60 - 16.399
40-16,0	16.40 - 17.199
40-16,8	17.20 - 17.999
40-17,6	18.00 - 18.799
40-18,4	18.80 - 19.799
40-19,3	19.80 - 20.799
40-20,3	20.80 - 21.799
40-21,3	21.80 - 22.790
40-22,3	22.80 - 23.790
40-23,3	23.80 - 24.799
40-24,3	24.80 - 25.999

[Click here to request free
Chip Deflector sample](#)

22

NOTE

These Chip Deflectors have smaller outside diameters than standard Chip Deflectors. They are designed for non U.S. made gun drill machines that require smaller outside diameters due to the chip box and bearing housing design. Order this style of Chip Deflector only if your machine requires it.

32mm OD Chip Deflectors also available for drill diameters 15.6 mm -25.999 mm. 40 mm OD Chip Deflectors also available for drill diameters under 15.6 mm. Contact us for a quotation.



Standard Design - Solid Plastic	Optional Steel Face on Both Sides
	<p>32mm x 11mm wide or 40mm x 12mm wide Contact for price and delivery</p>

Quantity discounts for individual sizes only

Part #	Pricing	Discounts
32-4,85 thru 32-6,0	\$4.28 each	10% off 100 pieces or more of any one size
32-6,05 thru 32-14,95	\$5.35 each	10% off 100 pieces or more of any one size
40-15,25 thru 40-24,3	\$6.42 each	10% off 100 pieces or more of any one size

**PRICING - US Dollars
Chip Deflectors**

Small Diameter Bushings

SnapGuide®



INTERNATIONAL
Drill Guide, INC.

T 864.225.2214
F 864.226.0832
gundrill.com

Click here to request free
Special Size SnapGuide sample

23

NOTE

Contour hole bushings in these ranges may contribute to premature drill breakage. Use these bushings at your own risk. Call us for contour bushings in this range and we will review your application.

PRICING - US Dollars
Small Diameter
Bushings

Small Diameter 17mm OD SnapGuide Bushings with Contour Hole

Bushing ID	Standard Part No.	Drill Range
2,0	2,0-17	2,1 - 2,199
2,87	2,87-17	2,9 - 3,099
3,07	3,07-17	3,1 - 3,359
3,27	3,27-17	3,36 - 3,459
3,37	3,37-17	3,46 - 3,799
3,55	3,55-17	3,8 - 3,959

Quantity discounts for individual sizes only

1-24	25-47	48-99	100+	Bearings	Snap Rings
\$6.15	\$5.62	\$4.55	\$3.48	\$8.56 (6003-2RS)	\$.27 (DSH-17)

Small Diameter 20mm OD SnapGuide Bushings with Contour Hole

Bushing ID	Standard Part No.	Drill Range
2,27	2,27-20	2,3 - 2,499
2,67	2,67-20	2,7 - 2,899
3,07	3,07-20	3,1 - 3,359
3,27	3,27-20	3,36 - 3,559
3,87	3,87-20	3,96 - 4,259

Quantity discounts for individual sizes only

1-24	25-47	48-99	100+	Bearings	Snap Rings
\$7.22	\$5.89	\$4.82	\$3.75	\$10.70 (6004-2RS)	\$.27 (DSH-20)

Small Diameter 30mm OD SnapGuide Bushings with Contour Hole

Bushing ID	Standard Part No.	Drill Range
2,67	2,67-30	2,7 - 2,799
2,87	2,87-30	2,8 - 3,099
3,07	3,07-30	3,1 - 3,359
3,27	3,27-30	3,36 - 3,459
3,37	3,37-30	3,46 - 3,799
3,55	3,55-30	3,8 - 3,959
3,87	3,87-30	3,96 - 4,259
4,27	4,27-30	4,5 - 4,749
4,47	4,47-30	
4,50	4,50-30	4,75 - 4,999
4,67	4,67-30	
4,87	4,87-30	5,0 - 5,249

Quantity discounts for individual sizes only

1-24	25-47	48-99	100+	Bearings	Snap Rings
\$8.29	\$6.96	\$6.42	\$5.89	\$13.91 (6006-2RS)	\$.27 (DSH-30)

15mm OD SnapGuide®

INTERNATIONAL Drill Guide, INC. T 864.225.2214 F 864.226.0832 gundrill.com

[Click here to request free sample](#)

PRICING - US Dollars
15 mm OD SnapGuide®

24

Extra Wide Drill Guides

Can't find the special bushing you need? Let us quote it!

[Click here to request free sample](#)

PRICING - US Dollars
Extra Wide Drill Guide

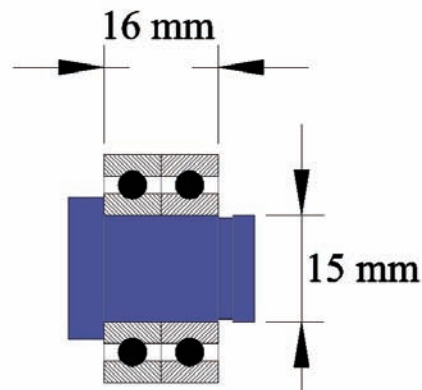

Bushing ID	Steadyrest Part No.	Appropriate Drill Sizes
5,75 6,0	5,75R-15 6,0R-15	Drill Range

Quantity discounts for individual sizes only

1-24	25-47	48-99	100+	Bearings (16002)
\$8.29	\$6.96	\$6.42	\$5.89	

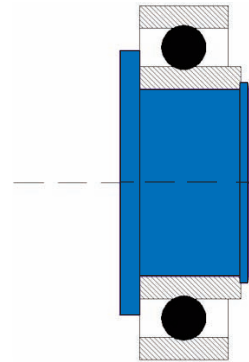

Bushing ID	Drill Guide Part No.	Appropriate Drill Sizes	Bearing ID	Bearing OD	Bearing Width
37,59	G400S	Drill Range			
39,37	G412S				
43,71	H460S				
45,87	H480S				
47,65	H490S				
48,82	H510S				

Quantity discounts for individual sizes only

Part #	1-9	10-24	25-47	48-99	100+	Bearing #	Price Each
G400S - G412S	\$12.31	\$11.50	\$10.43	\$9.90	\$9.36	8511	\$58.85
H460S - H510S	\$13.38	\$12.57	\$11.50	\$11.24	\$10.43	8513	\$75.97



Bushing ID

Part No.

Appropriate Drill Sizes
Drill Diameter

Bearing ID

Bearing OD

11,10	S11,1-17		17	35
12,93	S509-20		20	42
13,72	S540-20			
15,32	S603-20			
13,84	S548-30		30	55
14,71	S555-30			
15,24	S598-30			
15,37	S605-30			
17,48	S688-30			
19,00	S748-30			
19,99	S787-30			
21,56	S850-30			
22,05	S875-30			
22,56	S888-30			
23,06	S908-30			
24,84	S978-45		45	75
28,80	S1134-45			
31,09	S1224-45			
31,57	S1246-45			

Quantity discounts for individual sizes only

Part #	1-24	25-47	48-99	100+	Bearing #	Price Each
S11,1-17	\$6.15	\$5.62	\$4.55	\$3.48	6003-2RS	\$8.56
S509-20 thru S603-20	\$7.22	\$5.89	\$4.82	\$3.75	6004-2RS	\$10.70
S548-30 thru S908-30	\$8.29	\$6.96	\$6.42	\$5.89	6006-2RS	\$13.91
S978-45 thru S1246-45	\$10.70	\$10.17	\$9.10	\$8.56	6009-2RS	\$32.10



Bushing ID

Part No.

Appropriate Drill Sizes
Drill Diameter

Bearing ID

Bearing OD

9,6012	B378S			
9,6012	C378S	10,0 mm		
9,6012	C393C	10,0 mm		
	C463			
13,3952	C488S	13,0 mm		
	D591S			
15,113	D595S	15,5 mm		
15,9512	D628S	16,35 mm		
17,4752	D688S	18,0 mm		
18,0594	D711	18,24 mm		
19,4564	E766S	20,0 mm		
23,3172	E918			
28,9306	F1139S			
36,7284	G1446			
43,18	G1671			

Quantity discounts for individual sizes only

Part #	1-9	10-24	25-47	48-99	100+	Bearing #	Price Each
B378S	\$8.83	\$7.22	\$5.62	\$4.55	\$3.48	87008	\$14.98
C378S - C488S	\$9.10	\$7.49	\$5.89	\$4.82	\$3.75	87502	\$21.40
D595S - D711	\$9.36	\$8.29	\$6.96	\$6.42	\$5.89	87504	\$23.54
D115 - D185	\$9.36	\$8.29	\$6.96	\$6.42	\$5.89	87505	\$23.54
E766S - E918	\$9.63	\$8.56	\$8.03	\$6.96	\$6.42	87507	\$36.38
F1139S	\$11.24	\$10.43	\$9.36	\$8.83	\$8.29	87008	\$49.22
G1446 - G1671	\$12.31	\$11.50	\$10.43	\$9.90	\$9.36	6211-2RS	\$58.85

SnapGuide[®] for Allied Drills



INTERNATIONAL
Drill Guide, INC.

T 864.225.2214
F 864.226.0832
gundrill.com

Click here to request free sample

PRICING - US Dollars
SnapGuide[®] for Allied Drills

25

Drill Guides for Allied Drills

Click here to request free sample

PRICING - US Dollars
Drill Guides for Allied Drills

SnapGuide® Bushings for SUMOGUN Drills

INTERNATIONAL
Drill Guide, INC. T 864.225.2214
F 864.226.0832
gundrill.com

26



The color blue is a registered trademark of International Drill Guide, Inc.

SnapGuide® use on every gun drill machine.

Copyright © 2024 by International Drill Guide, Inc.

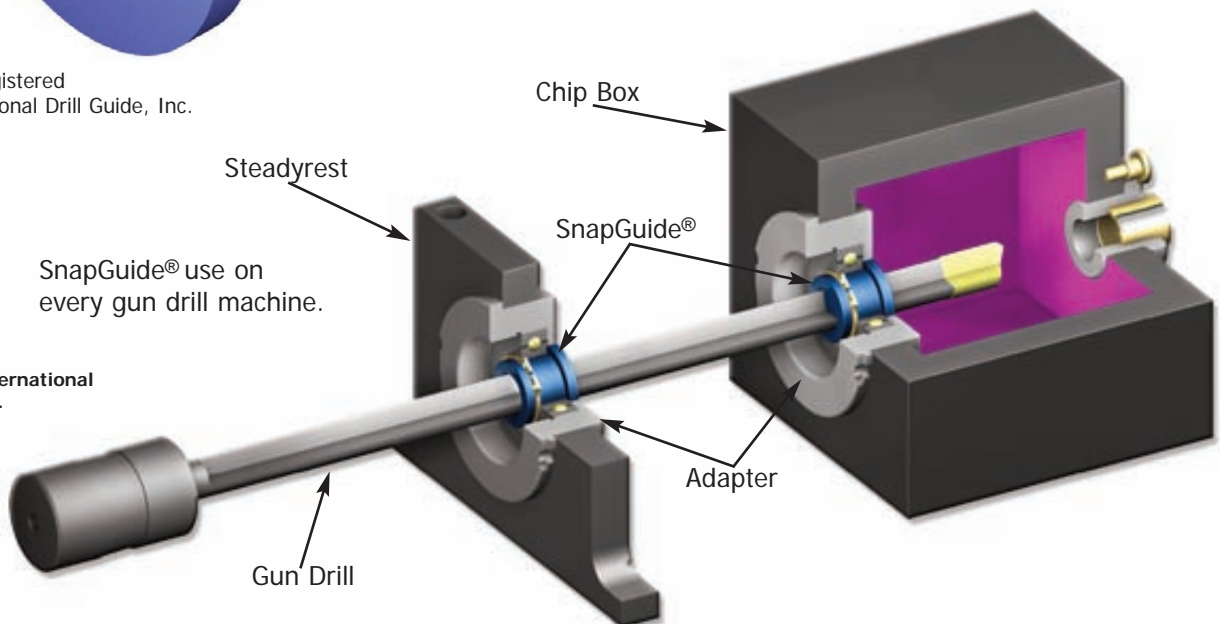

See our complete line of support bushings and seals for all deep hole tools at www.gundrill.com.

6006-2RS
Bearing*

Appropriate
Drill
Sizes

6206-2RS
Bearing**

SnapGuide®

SnapGuide®

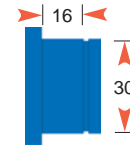

Drill Range

SI9,6-30	10,00 - 10,49	LSI9,6-30
SI10,1-30	10,50 - 10,99	LSI10,1-30
SI10,6-30	11,00 - 11,49	LSI10,6-30
SI11,1-30	11,50 - 11,99	LSI11,1-30
SI11,6-30	12,00 - 12,49	LSI11,6-30
SI12,1-30	12,50 - 12,99	LSI12,1-30
SI12,6-30	13,00 - 13,49	LSI12,6-30
SI13,1-30	13,50 - 13,99	LSI13,1-30
SI13,6-30	14,00 - 14,49	LSI13,6-30
SI14,1-30	14,50 - 14,99	LSI14,1-30
SI14,6-30	15,00 - 15,99	LSI14,6-30
SI15,4-30	16,00 - 16,99	LSI15,4-30
SI16,4-30	17,00 - 17,99	LSI16,4-30
SI17,4-30	18,00 - 18,99	LSI17,4-30
SI18,4-30	19,00 - 19,99	LSI18,4-30
SI19,4-30	20,00 - 20,99	LSI19,4-30
SI20,4-30	21,00 - 21,99	LSI20,4-30
SI21,4-30	22,00 - 22,99	LSI21,4-30
SI22,4-30	23,00 - 23,99	LSI22,4-30
SI23,4-30	24,00 - 24,99	LSI23,4-30
SI24,5-30	25,00 - 25,99	LSI24,5-30

[Click here to request free sample](#)

Bearing 6006-2RS* dimensions 55 mm OD X 30 mm ID X 13 mm wide
Bearing 6206-2RS** dimensions 62 mm OD X 30 mm ID X 16 mm wide

Quantity discounts for individual sizes only

1-24	25-47	48-99	100+	Bearings	SnapRings
\$8.29	\$6.96	\$6.42	\$5.89	\$13.91 (6006-2RS)	\$.27 (DSH-30)

PRICING - US Dollars
SnapGuide®

Bearing Adaptors

International Drill Guide Inc. has designed and manufactured a variety of special bearing adaptors to retrofit our products onto countless gundrill machines, transfer lines, and other special machines. We can help you retrofit our product simply and economically on any machine with little or no lead time. Most gun drill machine builders currently stock holders for our SnapGuide® or Drill Guide designed specifically for their machines. They are another quality source for your bearing adaptor inquiries.



The color blue is a registered trademark of International Drill Guide, Inc.

Request a Free Sample

Our top quality products save time and money. Prove it in your own plant. Fill out the request form below to receive your free trial sample.



Name Title

Company Tel

Fax E-mail

Address

City, State Zip country

Product requested

		DRILL TYPE (Check One)
SnapGuide® O.D.	<input type="text"/> Drill size	Single Flute <input type="checkbox"/>
Drill Guide	<input type="text"/> Drill size	Two Flute <input type="checkbox"/>
Chip Deflector	<input type="text"/> Drill size	Other <input type="checkbox"/>

International Drill Guide, Inc. Fax Number 864.226.0832